

A  
MANUAL  
FOR  
LEATHER ACCESSORIES  
AND  
LEATHER-WARE





# **MANUAL FOR LEATHER ACCESSORIES AND LEATHER GOODS**

**SUBRAMANIAN NATESAN**

Retired Scientist, CLAD



**CENTRAL LEATHER RESEARCH  
INSTITUTE, ADYAR, CHENNAI**

INDIA



## FOREWORD

Leather, as a commodity, is entering a centre stage in fashion world. Products made of genuine leather form symbol of prestige and pursuit of quality. In this backdrop, quality standardization in leather product industry in the world has attained special significance. While the aesthetic and artistic value of leather products cannot be compromised, standardization of quality is an integral need. In causing a transition of artistry and skill to professionalism and expertise, an important gap has been recognized in the global leather sector for long. The gap pertains to the paucity of adequate number and type of manuals on the conversion of leather into accessories and leather ware.

It is delightful that Shri Natesan has attempted to fill a much sensed gap by bringing out a "Manual for Leather Accessories and Leather Ware" It is a wonderful compilation which details the various steps involved in the manufacture of leather accessories and leather wares. Application to details is a critical need in conversion of leather into value added products. The manual of Shri Natesan has carefully brought out all the details needed in fabricating a standard leather product.

The manual displays the commitment of a master to share a rich experience gained over decades. It seems to be a good self-instruction material for technical personnel in manufacturing units of leather goods and leather garments. It is bound to serve a valuable guide and course material in imparting training in leather product sector.

The manual distinguishes itself by its uniqueness, depth and description of details. It is a valuable educational and training aid for those who seek excellence in their profession. In the generation of a technology culture in the leather product sector, this manual has made a valuable beginning. It is step forward. I congratulate Shri Natesan and his colleagues for the memorable effort and wish him well.



**Dr T Ramasami**

Director

Central Leather Research Institute  
Adyar, Madras 600 020

# PREFACE

Leather in various forms has for a long time been a major export earner of India. The growth in recent times of leather manufacture and production of leather goods, particularly garments have been phenomenal. Such growth stemming from the increasing demand of foreign countries has been backed up by developments in fashion design, patterns creation and techniques of fabrication. Simultaneous support in the form of simple as well as sophisticated tools, equipments and machinery has been forthcoming. Quality control, better management practices and response to functioning demands of export markets have contributed to Indian Leather and Leather Products Industry establishing itself as a notable player in the Global Arena.

Leather, of course, is the major input for the Leather Products Industry and, therefore, a knowledge or manufacture of different types of leather is a pre-requisite for undertaking products making. Further to produce quality leather products, floor-managers and shop-floor workers are required to master various techniques of fabrication and follow the advances in products making. Whenever needed, they have to be exposed to different types of tools, machinery, auxiliaries and techniques of application based on criteria such as standardization, quality, fashion and cost.

The present manual addresses itself to this task by presenting scientific material in an easy and readable manner. In this working manual, different chapters have been devoted to the process of Leather Manufacture, accessories, various tools, different types of machinery and their operational methods and working methodology in practice with suitable illustrations. Recent Technological advances in the products making have been indicated to stimulate the interest of those involved in designing, etc.

The author has made a sincere effort to describe in detail the fundamentals of leather goods manufacturing. The author also briefly introduces the fundamentals of garments manufacturing and wishes that the readers would utilize this basic knowledge along with the existing sophistication and technological advances in the manufacturing of leather garments. It is the earnest hope of author that the utility of the manual as a classroom text and a working manual will be enhanced by its constant exposure at the levels of workers, floor-level managers and students being trained in different centres of learning.

The Author wishes to acknowledge with thanks all the support he has been received from Dr. T. Ramasami, Director, Central Leather Research Institute and the heads of Leather Goods, Leather Garments and staff of Centre for Leather Apparels / Accessories Development.

**S. NATESAN**

# ACKNOWLEDGEMENT

I express my sincere thanks and gratitude to **DR. T.Ramasami**, Director, Central Leather Research Institute, Chennai, for providing me with all resources to help successfully complete “**A manual for Leather accessories and Leatherwear**”.

My wholehearted thanks and deep sense of gratitude to **Mr.T.K.Parthasarathi**, former Head, Centre for Leather Apparel and Accessories Development Division, Central Leather Research Institute, Chennai for his valuable guidance, suggestions and thoughtful comments in ensuring this manual meets the needs of the students taking course in the manufacture of Leather Accessories and Leatherwear. I am also grateful to him for proofreading my rough draft and adding to the accuracy and depth of the material.

I am elated in my endeavour to express my gratitude to **Dr.K.S.Jayaraman** and **Dr. T.S. Ranganathan** former Deputy Directors and Tannery Chief of Central Leather Research Institute, Chennai, for their guidance, technical editing, suggestions and encouragement in my effort to write the manual. They have been a tremendous source of inspiration for me in many ways.

My sincere thanks and gratitude to late **Mr. Basappa**, Assistant Director, CLAD Division, Central Leather Research Institute, Chennai for his valuable contribution, suggestions and guidance in **Leather Craft Works** in the manual.

My sincere thanks to **Mr. S. Ramakrishnan**, Head and all the staff members of Center for Leather Apparel and Accessories Development Division, Central Leather Research Institute, Chennai for providing me facilities and technical assistance to write the manual.

Finally, I would like to thank my wife for encouraging me to get this manual completed. I also would like to thank my son **Dr. N. Subramanian** and my grand son **C. Suprathik** for their technical support and assistance in bringing this manual to print. I would also like to acknowledge **Mr. C. Krishnan**, nephew, in helping to publish the manual on-line.



# CONTENTS

## Part I – Leather Goods

Foreword by Dr. T. Ramasami		iii
Preface		iv
Acknowledgements		v
Chapter 1	Processes of Leather Manufacture	1
Chapter 2	Introduction to Leathers and Leather Products	12
Chapter 3	Accessories	23
Chapter 4	Tools	37
Chapter 5	Leather Goods Machinery	52
Chapter 6	Technology of Leather Goods Manufacture	76
Chapter 7	Leather Craft Works	109
Chapter 8	Quality Control Aspects	124
Chapter 9	Projects for making Products	132
	References	136



# CHAPTER 1

## Processes of Leather Manufacture

Hide or skin is the natural covering material for an animal and performs the physiological functions during the lifetime and acts as a thermo regulator. Leather is produced from them through a series of processes detailed below (Fig. 1-1).

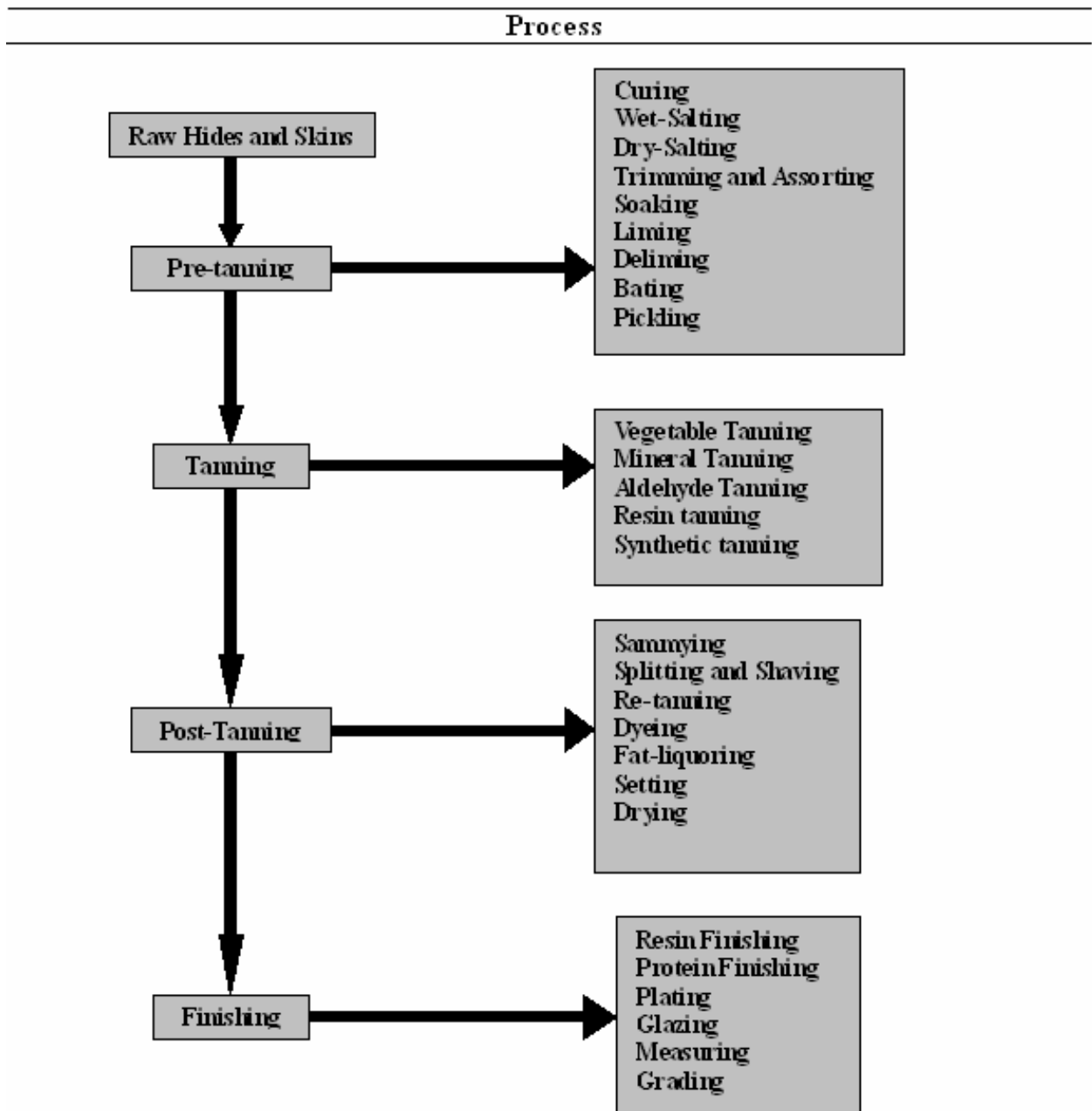

Fig.1-1: Leather processing – Sequence of operations

## **PRE-TANNING OPERATIONS:**

### **Curing, wet-salting and dry-salting:**

Once the animal is dead, bacteria begin to be active and putrefaction sets in. The process known as curing, in which the bacterial action is getting inhibited temporarily, preserves the hides and skins, which are removed from the carcass. During the process of curing, the skins are dehydrated and unfavourable conditions are created for the bacteria to grow. This is done primarily by the application of common salt on the flesh side of the skin using about 30 – 40% on the weight of the skin. Sometimes, the skins are dipped in a saturated brine solution and piled. In countries like India, drying in sunlight known as flint drying is done to remove the moisture (**Fig.1.2**).



**Fig.1-2: Curing**

### **Trimming and assorting:**

The cured skins, which arrive in the tannery, are first sorted out and trimmed. In the case of skins, they are ripped open and in the case of hides, they are cut into sides or processed as full hides as per the requirements.

### **Soaking:**

The next sequential operation is soaking of the skins in pits/paddle/drums (**Fig.1-3**). Preservatives and wetting agents are added in order to accelerate the processes of soaking and to prevent the bacterial action in the presence of water. During the process, the dehydrated skin is hydrated back and brought to the original condition, which existed when the animal was flayed.



**Fig.1-3: Soaking**

**Liming:**

During this process, chemical agents like lime and sodium sulphide are used to help in loosening the hair, open up the fibre structure and help in removal of the flesh layer and the other unwanted materials not required for leather processing. This is also done in pits or paddle or drums. After this operation, the hair and the adhering flesh are removed and the raw material at this stage is known as pelt (**Fig.1-4**). After liming, the pelt is pressed through a machine to remove fleshly tissue from the flesh side.



**Fig.1-4: Unhairing**

**Deliming:**

All most all tannages are carried out at low pH values. The lime that is present in the skin should be removed by the process known as deliming in which mild organic acid salts of weak bases like ammonium chloride, ammonium sulphate, etc, are used. The

lime is removed from the skin and the skin is ready for subsequent operations of bating, pickling, etc.

**Bating:**

This is carried out by enzymatic process in which some of the unwanted materials get removed and the pelt presents a cleaner appearance. This is mainly done for the skins.

**Pickling:**

The process of pickling is mainly done to condition the pelt to a stage at which they can be preserved for a long time and also can be assorted for different types of tannages. This is achieved by treating the pelt with common salt and sulphuric acid and pH of the pelt is brought to about 2.5 to 2.8 and sometimes preservatives are also added to keep the skins without any further damage for quite a length of time.

**TANNING OPERATIONS:**

**Tanning:**

Tanning can be defined as the process of converting the putrescence protein material into non-putrescence form and making the leather resistant to moisture and micro-organism. Different agents bring this about and these chemicals are known as tanning agents. Several tanning processes viz. vegetable tanning, mineral tanning, aldehyde tanning, resin tanning, synthetic tanning, etc. are used for tanning leathers (**Fig.1-5**).

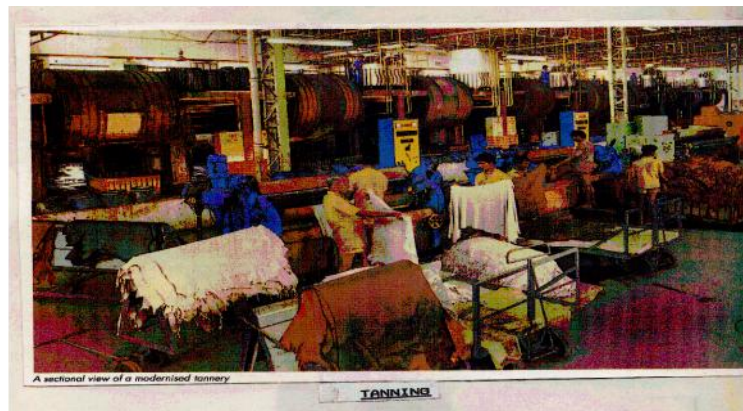

**Fig.1-5: Tanning**

**Vegetable tanning:**

This is a method in which the pelt is treated in an infusion of leaves/barks/nuts/roots.

**Mineral tanning:**

In this method, the most commonly used material is basic chromium sulphate and to some extent salts of aluminium and zirconium. Apart from it, other tanning agents like formaldehyde, fish oil, resin tannages, etc. are used. There are characteristic differences between mineral tannages and vegetable tannages. The chrome-tanned leathers are soft,

supple and stretch more than the vegetable tanned leathers. These tanned leathers are called wet-blue, which is the intermediate stage of leather processing (**Fig.1-6**).



**Fig.1-6: Wet-blue leathers**

#### **Aldehyde tanning:**

Aldehyde tanning is used to produce very soft white washable leathers usually from sheep or lamb skin with the grain split or shaved off. The leathers so produced are used for water washable gloves and clothing.

#### **Resin tanning:**

Resin tanning gives filler effect and grain tightening effect and reduces stretch. It provides good light fastness suitable for white leathers.

#### **Synthetic tanning:**

Synthetic tanning gives silky touch, tight and fine grain, surface feel, high degree of softness, light fastness, etc. to the leather. It is used to produce high fashion leathers.

The leathers, so produced depending upon the specific characteristics and nature, are used for different purposes. As a result of this variation in properties, in commercial practice, more than one tanning agent is applied, so that advantageous properties of different tannages could be imparted to the leather. After tanning, the leathers are subjected to post-tanning operations viz. sammying, splitting and shaving, neutralization, retanning, dyeing, fat-liquoring, setting, drying and finishing.

### **POST-TANNING OPERATIONS:**

#### **Sammying:**

Sammying is the process in which excess moisture is squeezed out by pressing through large rollers under pressure (**Fig.1-7**).





**Fig.1-7: Sammying**

**Splitting and shaving:**

The wet blue leather is split through the middle to the required thickness for end use. Any further reduction of thickness can be done by shaving off the unwanted fleshy material of the leather (**Fig.1-8**).



**Fig.1-8: Splitting and shaving**

**Neutralization:**

In the process of neutralization, the acidity of leather is removed and the leather is made to combine with subsequent chemicals that are used in latter stages in a more effective and uniform way.

**Re-tanning:**

In the process of retanning, synthetic tanning agents, resin tanning agents and vegetable tannins are employed and the various proportions are used depending upon the type of leathers to be produced.

**Dyeing:**

In the process of dyeing, the leather is made to combine with different types of dyestuffs and the colouring is imparted to the leather. The most important class of dyes that are used in the leather industry are anionic dyes, basic dyes and pre-metallised dye stuffs, each having its own property with respect to fastness to light, fastness to washing and penetrating capacity inside the leather. The tanner chooses his dyestuff depending upon the type of leather he is going to process.

**Fat-liquoring:**

In this operation, oil is introduced into leather in the form of emulsion, which breaks inside the fibre structure depositing a layer of oil or fat over the fibre structure. This helps in the fibres to move easily over the other giving sufficient softness and pliability to the leather. In this process, which is technically known as fat liquoring, emulsions based on vegetable oils, marine oils, animal fats and synthetic fats are used to get the desired property.

**Setting:**

The process of setting is done for smoothing the grain of the side and removing excess moisture so that the leathers are put in proper condition for drying.

**Drying:**

Drying is an operation, which removes water from the leather. Before leather is subjected to the drying process, the superfluous water, which is adhering to leathers, is removed for making the surface of the leather smooth. Then, the leathers are conditioned and set on the grain side. Setting is essential for removal of wrinkles and folds as well as for smoothening out coarse and drawn grain. Drying is an important function and needs a watchful eye. If the drying is slow, soft and spongy leather results. In case of vegetable tanned leathers, fungus and mould growth appear. If drying is too rapid, it gives hard leather. The last traces of water are removed by converting water into vapour by keeping the initial temperature of about 40 °C and relative humidity of 70% which is gradually brought down to 35 °C with a corresponding decrease in the moisture content of air. Vegetable tanned leather is dried at a fairly low temperature otherwise a darker colour results due to oxidation by vegetable tannins. Drying is carried out by toggle drying or vacuum drying. The leathers are stretched and kept over a metal frame by means of toggles. These are kept inside driers having controlled temperature and humidity. This obtains higher area yield. Vacuum drying imparts smoothness to grain and also increases yield. This method has the advantage of controlling the time cycle. After drying, the leathers are conditioned, staked and toggle dried for the process of finishing.

### **Staking:**

After the hides are dried, they become stiff and less flexible. The leathers are therefore staked by mechanical process to make the leather soft and supple (**Fig.1-9**).



**Fig.1-9: Staking**

## **FINISHING OPERATIONS:**

### **Finishing:**

In this operation, the leathers are subjected to the application of suitable finishing formulations based on binders, pigments, dyes, wax emulsion, etc. This surface coating not only helps to upgrade the leather by covering minor defects but also improves surface properties of the leather such as scuff resistance, water resistance that are necessary when they are converted into consumer oriented products. There are quite a number of finishes viz. resin finish, protein finish, etc. available in the market as well as topcoat formulations, which impart these characteristics.

### **Finishing techniques:**

#### **Coated finish:**

The leathers are finished by application of finish mixes to varying degrees. Depending upon the nature and coating applied, the leather surface and the defects can be covered.

#### **Natural grain finish:**

The leathers are finished with grain intact. The leathers should have good grain quality without deep scars or looseness.

**Full aniline finish:**

The leathers are dyed into a colour close to the required colour. Two or three coats of transparent finish with or without dye is applied which serves as a protection to the surface. Binders can be subjected to high temperature by friction to give a brilliant glossy look to the leather surface. These types of finishes enhance the natural appearance of the surface.

**Semi-aniline finish:**

Semi-aniline leathers contain small amount of pigments along with the dye to give coloured finish. The pigments used in the finish can cover minor scratches and superficial scars. They present a natural grain surface without too much of loading of the grain.

**Pigment finish:**

Pigment finished leathers are those types of finished leathers with relatively high amount of covering material. The covering of defects is very good in this finish.

**Imitation grain finish:**

These types of leathers are made from relatively poor quality hides. The hide surface has a number of deep scars and cannot be finished to a uniform look without modifications. So, the grain is removed by snuffing. Special resin binders are used to reduce the looseness of the grain layer and heavy finish coat is applied to get a uniform finished surface, which is embossed.

**Corrected grain finish:**

The crust is buffed to remove the top grain pattern and treated with a filling type of resin, which makes the grain layer tight. It is then embossed to stimulate an attractive grain surface. Special effects such as brush off effect can be obtained by using suitable binders and colouring mixes.

**Printed finish:**

These leathers are finished similar to corrected grain leathers, but with deeper print on the surface by embossing with suitable heat and pressure. A variety of print patterns such as crocodile print, lizard print, etc. can be effected.

**Split surface finish:**

Split leathers cannot hold the finish coating well due to its coarse and fibre network. Special techniques can be used to apply finish coatings on the split surface to upgrade the performance similar to finished leathers.

**Nubuck finish:**

The leathers are finished with velvet like surface on the grain layer. Since the fibres in the grain layer are compact and short, the nap is fine and smooth and the textured surface will show a difference in shading when run by the hand over it.

**Oil pull-up finish:**

Special oils are applied on the surface of the leather with or without transparent finish coatings. The oils provide protection as well as a unique look to the surface. Oil pull-ups

are made from full grain leathers with application of oil. The oil can migrate when pressure is applied on the surface and come back when the pressure is released. Thus, the surface will show two-tone effect when pressed or pulled.

### Antique finish:

The leathers are applied with special wax to the buffed grain surface. The wax can melt and migrate under frictional heat. Because of this, when the surface is rubbed, the colour of the rubbed portion changes which does not reverse immediately. This shows an antique effect.



**Fig.1-10: Finishing**

### Plating:

Plating is a mechanical smoothening of the finished leathers. It is the process in which a texture can be created on leather by impressing it with a pattern. Some of the leathers are given plating, which may be smooth plating in hydraulic press or continuous plating in a feed through machine. It is also possible by means of hydraulic press to impart the various types of designs on to the surface of the leather, which is known as embossing. In recent years, there has been a lot of development on newer embossing machines, which produce various types of effects on the surface of the leather so that they can be used for a variety of purposes (Fig.1-11).

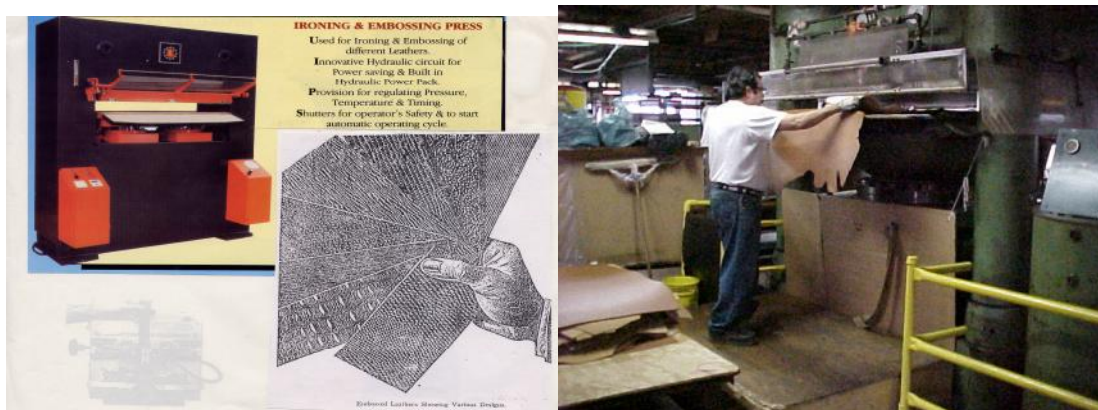

**Fig.1-11: Plating**



**Glazing:**

Glazing is known as top coating. In this process, a clear aqueous finish is commonly applied to protect the grain surface of the leather. The leather surface is then polished to a high lustre by the action of a glass roller under pressure, which operates like a giant arm.

**Measuring:**

Almost all the leathers are measured by area, which is done either by a mechanically operated machine or electronically operated machine and the area is indicated in leather as square feet or square decimetre (**Fig.1-12**).

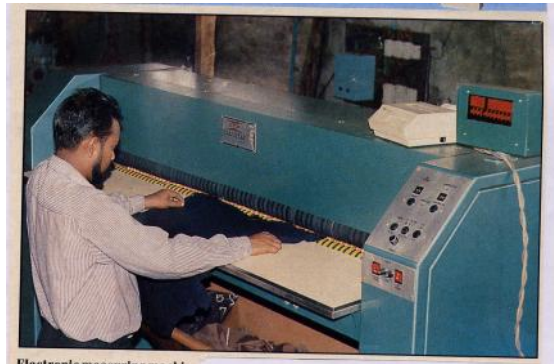

**Fig.1-12: Measuring**

**Grading:**

All the leathers are finally graded mainly by visual examination and a lot of expertise is needed. Depending upon the grain characteristics, feel, substance, etc., every batch of leathers is normally given number of grades with each one fetching different prices (**Fig.1-13**).



**Fig.1-13: Grading**

**Quality control:**

In the process of leather manufacture, apart from various chemical operations that have been mentioned earlier, there are a number of mechanical operations, which also affect the quality of the leather. Some of the mechanical operations involved are: (a) splitting and shaving by which an uniform substance is obtained (b) staking by which leathers are conditioned and made soft by staking the fat-liquored leathers (c) drying in which the leathers are dried to the desired extent without affecting the feel of the leather (d) buffing in which the clean flesh side is produced and improvement is effected on the flesh side.

Thus, one can appreciate that in the process of leather manufacture, there are so many controlling factors and it is necessary that standardization and quality control be maintained in each stage of leather processing so that the quality of the leather produced will be of a consistent quality from which various consumer products can be produced.

# Chapter 2

## Introduction to Leathers and Leather Products

### INTRODUCTION TO LEATHER:

Leather has been playing its own role in day-to-day life of mankind from time immemorial. Leather was used for carrying out some basic activities of man such as carrying water, covering the body to protect from cold climatic conditions etc. The first apparel that adorned the primitive man's torso was made of skin. Man has come a long way from the days of primitiveness and so also leather. In today's life, the role of leather is varied and vast. The products made out of leather lend themselves to an enormous variety of items, which are a need and asset in modern living. An extensive range of colours and designs widen the selection range, which encourages the consumers to put these products to use in a multitude of ways be it fashionable or functional.

In the global leather products industries, cattle, buffalo, goat and sheep are the major livestock species contributing the basic raw materials. Although, pigskins, skins of reptiles and various fur animals are also used as raw materials, their use is limited to a few countries.

### Hide and skin:

The names of leathers themselves are fairly descriptive. The suffixes hide and skin, tell the relative size of the animal. The body covering of big animals' viz. buffalo and cattle is called hide. It is longer in size, thicker in substance and heavier in weight. If the hide is vertically cut at the centre, the two pieces of the hide are called sides. The body covering of smaller animals' viz., calf, goat, sheep, etc. is called skins. It is smaller in size, thinner in substance and lighter in weight. The body covering of wild animals viz. lion, tiger, elephant, etc. are also called skins. The skins of lizards, snakes and crocodiles are called exotic skins. A kip is a small hide. The hair or outer side of the skin is called the grain side and the inner side of the skin is called flesh side. Leather is tanned and finished so that the grain side has a smooth rich surface (**Fig. 2.1**).

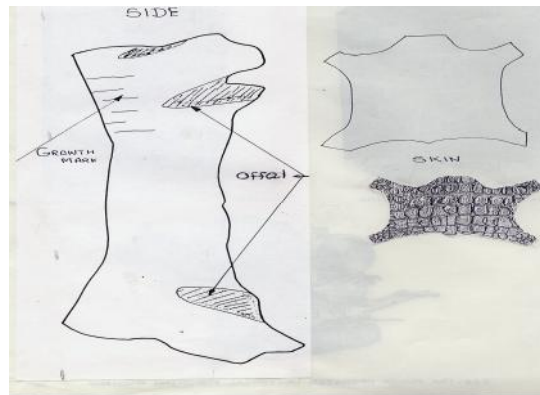

## Fig. 2.1 Side and skin

### **Characteristics of leathers:**

Each type of leather is suited to a range of uses, according to its unique characteristics. Choosing the right one for the job is easy, once you know what to look for. Leather is tanned and finished on the grain side to have a smooth rich surface. Leather, which is tanned and finished on the flesh side, is called suede. Various types of finished leathers, which are used for making leather products, are described below:

### **Hides and sides:**

#### **Buff hides:**

Buff hides are thick, strong and durable. Buff uppers and buff softy uppers are finished in a few shades. They are used for making heavy and luggage leather goods.

#### **Cowhides:**

Cowhides are thick, strong and durable. They have smooth grain surface. Cowhides are finished in different colours with different techniques and are used for making a wide range of leather goods. Most commonly used finished cow hides are:

#### **Box sides:**

Box sides are black in colour with distinct surface grain. Box sides are used for making heavy leather goods.

#### **Willow sides:**

Willow sides are brown in colour with distinct surface grain. The name "willow" is derived from willow tree. Willow sides are used for making heavy leather goods.

#### **Cow dry-milled uppers:**

Cow dry-milled uppers, which are tanned with characteristic grains, developed naturally. The techniques of embossing in the hydraulic embossing press are also done to get characteristic grains. Cow dry-milled uppers are used for making heavy, medium and small leather goods.

#### **Cow napa leathers:**

Cow napa leathers are soft and have larger area with increased cutting value and smoothness of grain. Cow napa leathers are used for making softy types of leather goods.

#### **Case sides:**

Case side leathers are firmly dressed leathers. They are stained or otherwise coloured with smooth glossy finish. Case side leathers are used for making heavy leather goods.

#### **Kattai leathers:**

Kattai leathers are finished with smooth glossy finish and are generally manufactured in black or brown colours. Kattai leathers are used for making heavy leather goods and box type goods

#### **Upholstery leathers:**

Upholstery leathers are finished in attractive colours with design printing. Upholstery leathers are largely used in furniture and automobile industries.

#### **Split leathers:**

Split leathers are under layers of buff and cow hides (flesh side). Split leathers are up-graded by special finishing techniques in attractive colours. They are either plainly finished or printed with

## **Skins:**

### **Buffalo/cow calfskins:**

Calf is the term generally used to describe an animal in suckling stage. Dyed calfskins are very rich in appearance and have a soft smooth satin-like finish. These skins are used for making small and sophisticated leather goods. Naturally finished cow calf skins (E.I. tanned) are used for making leather crafted goods decorated with tooling, carving, embossing and burnished works.

### **Goat Skins:**

Goatskins are strong, durable soft skins. Goat skins have characteristic patterns, which give a unique look to the products. Their fibres are short and compact. Naturally finished goat skins (E.I. tanned) are used for making leather goods with carving, tooling and embossing works. Most commonly used finished goat skins are:

#### **Goat uppers:**

Goat uppers are tanned and finished in attractive colours. Goat uppers are used in making small leather goods.

#### **Glaze kids:**

Glaze kids, made from goatskin, are tanned with smooth and bright glossy finish. Glaze kids are generally used for making novelty goods.

#### **Morocco leathers:**

Morocco leathers are fine and lovely finished goatskins. They are thin but longwearing and come in a limited number of colours and are especially known for its rich red hue. They are tanned with characteristic grains developed naturally. The techniques of hand boarding or embossing are used to get characteristic morocco grains on the surface of the skins. Morocco goatskins are mainly used for making billfolds.

#### **Sheepskins:**

Sheepskins have a smooth grain and its strength properties are less as compared to goatskins. Sheepskins are good starting materials for making softy types of leather goods, particularly, ladies handbags, wallets, etc.

#### **Sheep and goat napa leathers:**

Soft full grain napa leathers made from goat and sheep are extensively used for making softy types of leather goods and leather garments.

#### **Sheep and goat suede:**

Suede leathers are characterized by its fine velvet nap normally on the flesh side. Suede leathers are made from goat and sheep. Since suede leathers have high degree of softness, light in weight and reasonable stitch-tear and tongue-tear strength, they are used in most fashionable leather goods and leather garments. Inferior quality suede leathers are used as linings in leather goods.



**Skivers:**

Skivers are the outer or grain splits of sheep or lambskins. The thickness of the skin usually varies from 0.2 mm to 0.5 mm. Skivers are finished in attractive colours and are used as linings in leather goods.

**Chamois skins:**

Chamois skins are made from flesh-split of sheep or calfskins from which the grains are removed. Chamois skin is tanned with fish oil to make the skin very soft and supple. It is suede on both sides. Chamois skins are inexpensive and widely used in filtering gasoline and optical and ornamental industries. They can also be used for making leather garments.

**Pigskins:**

Pigskins are tanned and finished with grainy structure with distinctive cluster of marks where the bristles are located. They can be buffed to a matte finish, polished for a shiny effect or napped and suede. Pigskins are used for making novelty products and leather garments.

**Fur skins:**

Fur skins are generally made from rabbit, deer, wildcat, fox, etc. The skins are processed with hair-on tanning techniques using alum, zirconium and chrome. Fur skins are tanned and processed to make it soft and supple. They can be sheared, bleached, dyed, let out or curled to make it more interesting. They are used in cap, glove and garment industries.

**Exotic skins:**

The skins of reptiles are called exotic skins. The reptiles are crocodiles, alligators, lizards, cobras, pythons, etc. These are classified under endangered species.

**Crocodile/alligator skins:**

Since the back of the crocodile/alligator skins are heavily scaled, coarse and horny, only their bellies with striking patterns are used. Crocodile/alligator skins, finished in attractive colours, are used for making exclusive leather goods. viz. wallets, ladies handbags, jewellery boxes, etc.

**Lizard skins:**

Lizard skins are tanned and finished with characteristic grains in charming shades. They are used for making ladies handbags, wallets, watchstraps, etc.

**Python skins:**

Python skins, which are finished with striking patterns and beautiful shades, are used for making sophisticated ladies hand bags. The average length and width of the python skin will be 2 to 4 meters long and 20 cm.wide.

**Cobra skins:**

Cobra skins are tanned and finished with beautiful scale patterns. Cobra skins, finished in attractive colours, are used for making ties, belts, wallets, etc.

**Introduction to leather products:****Leather goods:**

The term "leather goods" is applied and generally confined to articles made mainly of leathers and intended to carry personal belongings. Some articles are carried in pockets and some are carried in hand or shoulder. The variety of leather goods we come across

every day is countless. When there are a variety of articles that differ in sizes, shapes, designs and methods of constructions, it is absolutely necessary to classify them into separate convenient articles of similar kind. Leather products are broadly classified into leather goods, leather garments, footwear, gloves, sports goods and harness and saddlery.

**Leather goods:**

Leather goods are broadly classified into small leather goods or personal leather goods; medium leather goods; heavy leather goods/luggage goods and ladies handbags (Fig.2.2).

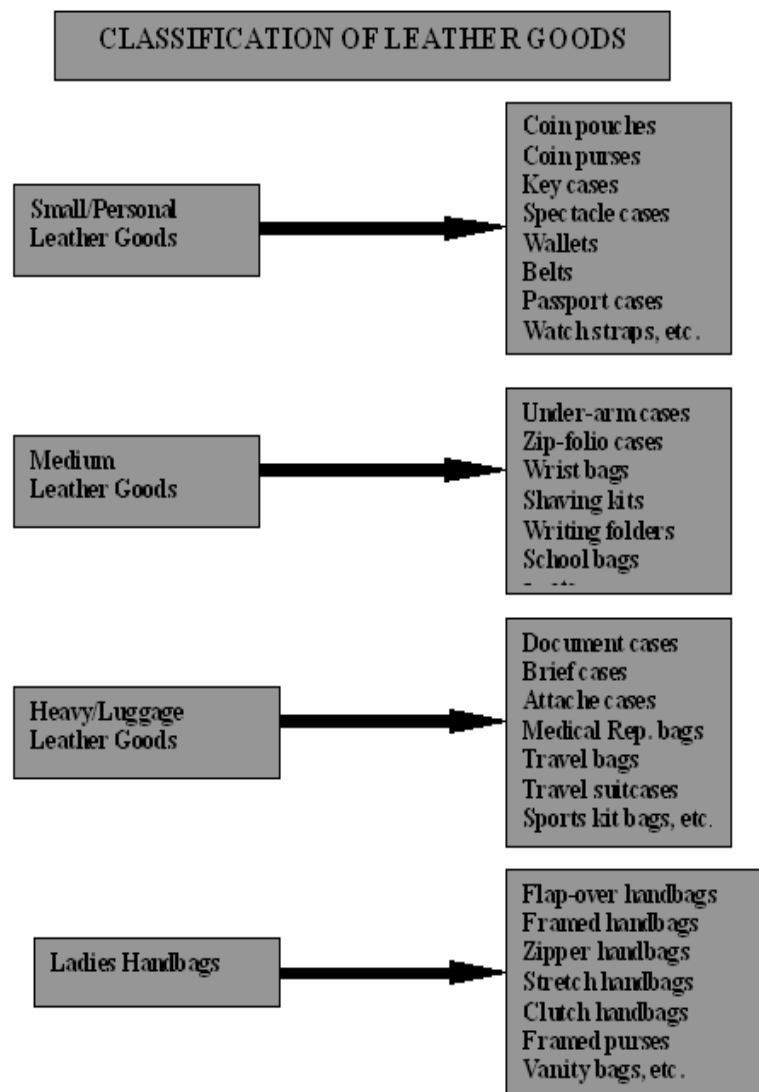

Fig.2-2: Classification of leather goods

**Small leather goods or personal leather goods:**

Small leather goods or personal leather goods are usually carried in pockets. Small leather goods are generally made from cow calf, buff calf, goat, sheep, pig and exotic skins with different finishes. The thickness of leather required for making small leather goods is about 0.5 mm to 0.8 mm. e.g. coin purse, coin pouch, key case, belt, wallet, spectacle case, passport case, watch strap, etc. (Fig.2.3)



**Fig.2.3 Small leather goods**

**Medium leather goods:**

Medium leather goods are generally made from cowhides with different finishes. The thickness required for making medium type of leather goods is about 0.8 mm to 1.0 mm. e.g. under-arm case, wrist bag, zip folio bag, school bag, shopping bag, shaving kit, gents shoulder bag, etc. (Fig.2.4)



**Fig.2.4 Medium leather goods**

**Heavy leather/luggage goods:**

Heavy leather goods /luggage leather goods are generally made from buff and cow uppers and softy uppers with different finishes. The thickness required for making heavy/luggage leather goods is about 1.0 mm to 1.2 mm. e.g. document case, portfolio bag, medical representative bag, brief case, travel bag, travel suitcase, etc.(Fig.2.5)



**Fig.2.5 Heavy/Luggage leather goods**

**Ladies handbags:**

Ladies handbags are manufactured in a fascinating array of designs with exiting colour combinations, which make its look up when carried. Hand bags are used for many purposes viz. formal leather bag in classic style for work, a fun funky bag in a bright colour for afternoon lunches and a stylish clutch or sequined purse for an evening out. Since ladies handbags are considered to be the most fashionable goods, they are made in attractive designs using eye catching coloured finished leathers. Ladies handbags are generally made from the skins of cow upper, cow softy upper, aniline buff calf, aniline cow calf, aniline goat, coloured goat, goat napa, sheep napa, goat suede, etc. Apart from above mentioned leathers, exotic skins like crocodile skins, lizard skins, python skins, cobra skins, etc. finished in attractive colours are also used for making handbags. The thickness required for making ladies handbags is about 0.6 mm to 0.8 mm. e.g. framed purse, pouch bag, framed hand bag, flap-over hand bag, zipper hand bag, stretch bag, etc. (Fig.2.6)



**Fig.2.6 Ladies handbags**



**Fig.2.6 Ladies handbags – Exotic skins**

### **Leather Garments**

Garment leathers and ready-made leather garments are largely exported to West and European countries. These are mainly made from sheep, goat and cow napa. Sheep skins are the unique materials for making leather garments when compared with goat and cow because of feather touch feel, softness and smooth grain. Sheep skins are the ideal raw material for making leather garments because they have supple and fluffy feel, light weight, fashion appeal and wear resistance. Even though sheep is the best raw material for making leather garments, cow napa is also preferred for making leather garments due to larger area with increased cutting value and smoothness of grain. Pigskins and upgraded soft splits are also used for making leather garments. The important characteristics desired in garment leathers are: (i) good drape, (ii) softy and fluffy feel, (iii) light weight, (iv) fastness to dyeing, (v) good dry and wet resistance, (vi) cold crack resistance, (vii) good stitch-tear and tongue tear resistance (**Fig.2-7**).

### **Footwear:**

Footwear is one of the products that substantially earns the much-needed foreign exchange. In the recent years, the developments in the shoe manufacturing have shown a considerable progress to comply with the ever-changing demands of fashion. Shoe uppers are usually manufactured from uppers and softy uppers of cow, buff and goat. Apart from these, new buck leathers, burnished leathers and split suedes are also used in the manufacturing of shoe uppers. Lining leathers are produced by traditional and natural vegetable tanning process. They have greater absorption qualities than chrome tanned leathers. As the leather is used inside of the shoe, it is a significant benefit. Leather soles are produced from buff hide with bark tanning process. Since the fibres get tightly interwoven, it becomes strong and durable. Additionally, they are flexed to make them comfortable in the extreme. A variety of synthetic soles are also used in shoes. Shoes, slippers and sandals are manufactured in a wide array of comfy leather in various colours and designs. Full shoes with basic styles of Bromol, Derby, Moccasin, Oxford, Pump, Loafer, Boot, Sandal, etc. are manufactured from the above leathers and exported (**Fig.2.7**).





**Fig.2.7 Leather garments and Footwear**

**Gloves:**

The leather glove is an ideal barrier between the objects to be picked up and the skin of the hand, because of the excellent sense of touch it provides. It is heat-transfer resistant and a good low voltage insulating material. Gloves are made by cutting suitable leather using steel dies and a hydraulic press. They are then stitched by using specialized sewing machines. Triad, a monolithic, hydrophilic, thermoplastic copolymer membrane is used as glove inserts. There are three types of gloves viz. industrial gloves or work gloves, dress gloves and sports gloves (**Fig.2.8**)



**Fig.2.8 Industrial and dress gloves**

Industrial gloves are manufactured according to the specific needs of the industries with the inner reinforcements such as metal plates, asbestos, wadding etc. These leather gloves are largely used in steel, chemical and glass industries. Industrial gloves are usually made from buff and cow chrome crust splits. The dress gloves are mainly used in

cold countries to protect the hands from acute cold weather. They are generally made from hair sheep, wool sheep and lambskins and to a lesser degree from deer, pig, goat and kidskins. Sports gloves are used to protect hands during sports events. They are also made from the same leathers, which are used for dress gloves. e.g. horse riding gloves, motor bike riding gloves, golf gloves, etc. Glove sizes for ladies and gents are given in the table below (**Table 1**):

**Glove sizes:**

Ladies	Gents
<b>S = 6-1/2</b>	<b>S = 8</b>
M = 7	M = 8-1/2 to 9
L = 7-1/2	L = 9-1/2 to 10
XL = 8	XL = 10-1/2 to 11

Table -1 Glove sizes

**Sports Goods:**

**Football, volleyball, basketball and rugby ball:**

These sports goods need leathers of perfectly elastic without any residual stretch as most of the leathers go out of shape either during manufacturing process or after games. These goods are manufactured from cow hides having a weight range of 10 to 15kgs, tanned with bag tanning first and then retanned with vegetable tanning. Bag tanned and retanned leather butts are cut and shaved to the required thickness after wetting back. These are again semi chrome tanned and finished in desired colours with zero stretch. The leathers are then used for making the above sports goods.

**Steps involved in football production:**

Panel cutting machine makes the leather panels. The panel cutting machine, besides making the panels, also makes perforations on all sides of the panels for stitching. The shape of the panels depends on the number of panels to be used in the manufacture of the ball. Footballs are usually made of either 18 or 32 panels. For the footballs exported to the United Kingdom, 18 panels are used while for all other countries, it is generally 32 panels. The design and logo of the panels are first made on the leather and then they are cut into panels. When the panels are ready, the central panel is pasted on a rubber bladder. The complete set of panels for each ball is then arranged for final stitching. After the balls are stitched, they are checked for quality (**Fig.2-10**).

**Cricket ball and hockey ball:**

Cricket ball and hockey ball leathers are also made stretch less like football, volleyball etc. Bag tanned cowhides of weight range 6-7 kg per side are taken. The sides are dipped in water, sammed, split and shaved to about 2.5mm thickness. This is then bleached and retanned by alum tanning process. After retanning, the leathers are brush dyed with a dye solution and nailed wet on board after stretching them to get 0% stretch. After dyeing, lacquer is applied and then finished either in white or red colour.

**Steps involved in cricket ball production:**

Four pieces are cut from one butt to match in both colour and weight. These are machined with 1.2 mm. braided polyester thread forming an invisible seam (flat seam). They are then pressed in warm moulds with the counter weights in place to form them into ball shape. They are allowed to season before being trimmed for size. Two false rows of stitches are added. The covers are then matched to a core of correct size and weight, pressed together in a vice and hand stitched to close the ball. The 5/18-waxed thread is used and about 81 bonded lock stitches are done. After stitching, the balls are checked for quality. Top grade four piece balls are manufactured using the traditional quilted or layered core. Core is a moulded cork and rubber centre. These are then layered with yarn and more cork. The wool yarn is wound wet under tension to compress each of the cork layers to produce a core with the required bounce and shape retention qualities (Fig.2-10).

**Wicket keeping glove leathers:**

They are generally made from cow calf leathers. They are chrome tanned, mordanted with vegetable extract, dyed in either yellow or black and resin finished. Since cow calf is very expensive, bag tanned offal/bag tanned bellies are retanned with aluminium sulphate, sodium acetate and soda ash. They are then dyed in suitable colours for manufacturing wicket-keeping gloves. These leathers have properties similar to the leathers made from cow calf and are cheaper to manufacture (Fig.2.10)



**Fig. 2.10 Sports goods**

### **Harness and saddlery:**

Harness and saddlery are manufactured from vegetable tanned cattle hides. A considerable quantity of pigskins is used for making saddle seats. Harness and saddlery are usually finished in natural tan shade. They are flexible and mainly used for horse riding (**Fig.2.11**)

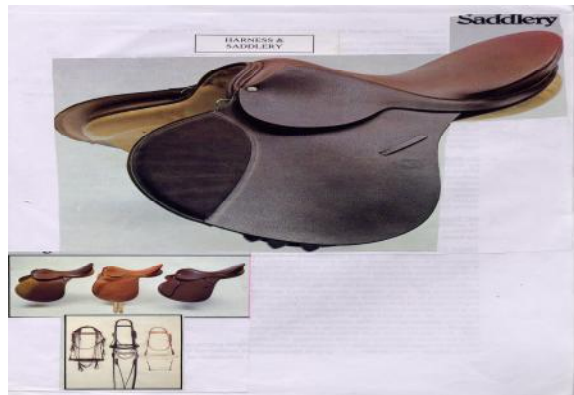

**Fig. 2.11 Harness and saddlery**

# Chapter 3

## Accessories

Accessories play a vital role in the manufacture of the leather goods because they are used for various functions viz. to open and close, to provide strength and durability, to hold, to join, to stitch, to improve elegance and beauty, etc. Accessories are grouped into 1. fittings, 2 linings, 3. adhesives, 4. threads, 5. needles and 6.other miscellaneous items.

### 1. Fittings:

Fittings, described below, are manufactured from metals and metal wires coated with brass or chromium or anodize in matt or high glossy or antique finish. Imported and superior quality fittings are used in leather goods which are sold in external markets while ordinary metal fittings plated with brass or chromium or anodized are used in leather goods which are sold in internal markets. Fittings comprise of (i) locks (ii) frames, (iii) strap fittings, (iv) gusset fittings (v) handle fittings, (vi) hooks, (vii) hinges, (viii) clips and (ix) fasteners.

#### (i)Locks:

Locks are manufactured in different sizes, shapes and styles and are used as closing device in leather goods. Locks may or may not have locking arrangements. They are generally used in heavy luggage and moulded leather goods. e.g. suitcase locks, brief case locks, document case locks, camera case locks, fancy locks (for exclusive leather goods like jewel box, cosmetic box, etc.), zip locks, magnetic snaps, clip locks, etc. (Fig.3-1).



Fig.3-1: Suitcase, brief case and document case lock

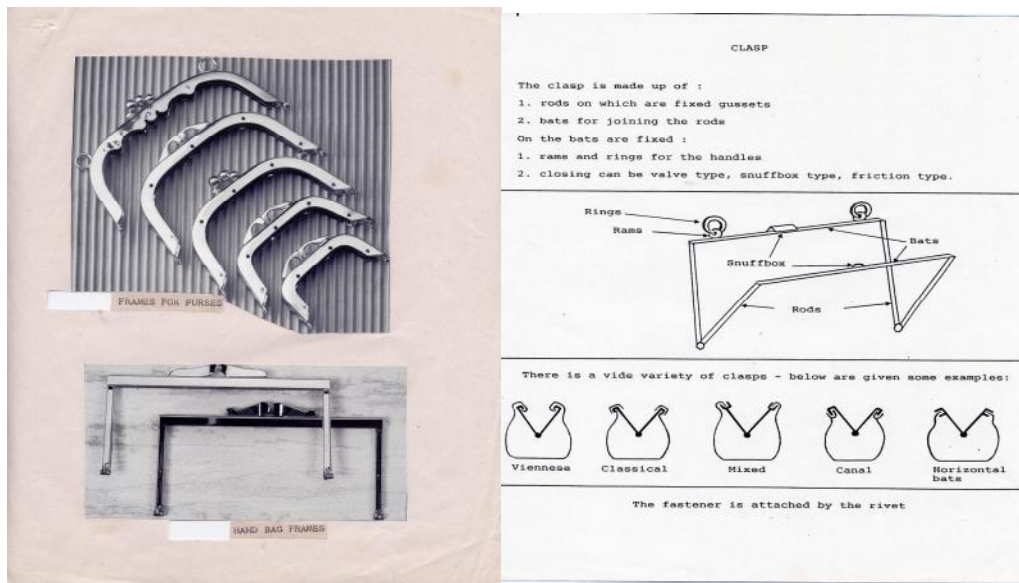



**Fig.3-1: Camera case locks, fancy locks, zip locks, magnetic snaps and clip locks**

**(ii) Frames:**

Ladies handbag frames are manufactured in different shapes, sizes and styles. Smaller frames of sizes 8cms to 15cms are used for making framed purses and pouches while bigger frames of sizes 18cms to 30cms are used for making framed handbags. Handbag frame is made of: rods—for gusset fittings, bats—for joining the rods, rams and rings—for handle fixing and closing can be a valve type or snuff box type or friction type (**Fig.3-2**).



**Fig.3-2: Handbag frames and description of parts of a handbag frame**



**(iii) Strap Fittings: (Fig.3-3).**

**(a) Rings:**

Rings are manufactured in different sizes and shapes and are used for fixing handles and shoulder straps.

**(b) Belt buckles:**

Belts are an essential accessory to any wardrobe. Belt buckles should be sleek. Belt buckles are manufactured in different sizes and shapes and are used in making belts. 25mm, 30mm and 35mm buckles are used in gents' belts. 50mm and 70mm buckles are used in police, army, pouch and fancy ladies belts.

**(c) Roller buckles:**

Roller buckles are manufactured with metallic sleeve and hook. The sleeve of the buckle permits the leather strap to slide over it easily and facilitates the buckle hook to engage into the hole of the leather strap. They are used as a closing device in bags. Roller buckles are largely used in document cases, school bags, conductor bags, etc.

**(d) Adjustable buckles:**

Adjustable buckles are manufactured in different sizes, shapes and styles. They are used in ladies and gents' shoulder bags. The length of the shoulder straps can be adjusted by using these buckles.

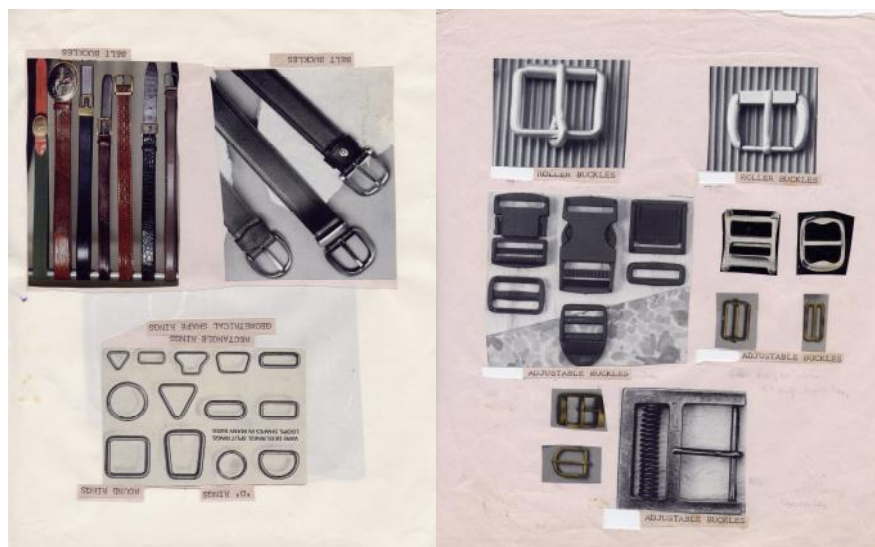

**Fig.3-3: Rings, belt buckles, roller buckles and adjustable buckle**

**(e) Watchstrap buckles:**

Watchstrap buckles are manufactured in different sizes and shapes. 9mm, 10 mm and 12 mm watchstrap buckles are used in ladies watchstraps while 14mm, 16mm and 18 mm watchstrap buckles are used in gents' watchstraps (**Fig.3-4**)



**(vii) Hinges:**

Metallic hinges are manufactured in different shapes and sizes and are used in travel suitcases, brief cases, cosmetic boxes, jewel boxes etc (Fig.3-5).

**(viii) Clips:**

Metallic corner clips are used as decorative fittings. They are manufactured in different sizes, styles and shapes. They are used in document cases, folders, wallets, passport covers, etc. In billfolds, spring type clips are used to hold currencies (Fig.3-5).

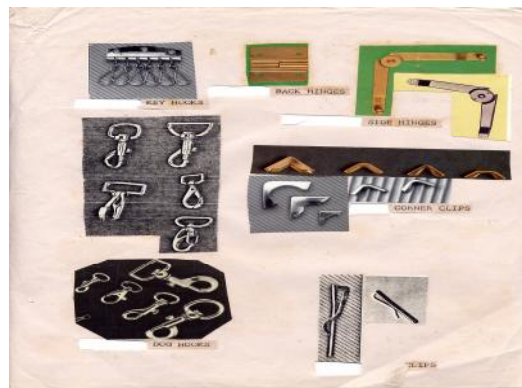

**Fig.3-5: Key hooks, dog hooks, hinges and clips**

**(ix) Fasteners: (Fig.3-6).**

**(a) Rivets:**

Rivets are manufactured in two types. They are bifurcated rivets and lock rivets. The rivet has a cap and a split stem. Bifurcated rivets are used for fixing handles in leather goods where considerable strength is necessary while lock rivets are used for fixing locks.

**(b) Rivet Buttons:**

Rivet buttons are used as fastener in a variety of leather goods. A rivet button has two parts. The upper part is a hollow cap and the bottom part is a cylindrical stem with base. While joining components, the bottom stem is pushed through the punched hole and the cap is pressed over it. The riveting is done by riveting tool. Black, brown, and other colour rivet buttons are used to match the colour of the products.

**(c) Eyelets:**

Eyelets are manufactured in different shapes and sizes. Small eyelets are used in key cases, belts, leather straps, etc. while big and fancy eyelets are used in stretch ladies handbags.

**(d) Studs:**

Metal and plastic studs are manufactured in a variety of shapes and styles, viz. cylindrical, conical, half-moon etc. and are used in box type of leather goods. They prevent the products from abrasion due to keeping them frequently on floor. Studs are used in brief cases, suitcases, jewel boxes, cosmetic boxes, etc.

**(e) Purse Buttons:**

Purse buttons otherwise called snaps are used in leather goods. A purse button has four parts. They are cap, cap spring rivet, snap and snap rivet. These parts are fitted into leather goods by an appropriate button-fitting tool viz. 3/2, 3/3, 4/3 and 7/7. Purse buttons are used as a closing device in pockets. Purse buttons are also used in gent's belts to hold the buckle. In Shoulder bags, purse buttons are used for making suitable adjustments in the length of the strap. Purse buttons of sizes 3/2,3/3,4/3 are used in small and medium leather goods while purse buttons of size 7/7 is used in heavy leather goods.

**(f) Zips:**

Zips may be metallic or nylon and are manufactured in attractive colours to match the colour of the products. Zips are manufactured as rolls and sold in meters. No.3, No.5, and No. 7 zips are used in making leather goods. No. 3 zips, which have small teeth, are used in small leather goods, No 5 zips, which have medium teeth, are used in medium leather goods and No 7 zips, which have big teeth, are used in heavy leather goods. Zip is a closing device and is used in a variety of leather goods. It is extensively used in leather goods because it is ready made, it can cover a long opening in a minimum time and it is a quick device of closing. Zips are used in pouches, wallets, ladies handbags, zip folio cases, travel bags, travel suitcases, etc. It is also used as a closing device in pockets.



**Fig.3-6: Rivets, rivet buttons, eyelets, studs, purse buttons and zips**

**2. Linings: (Fig.3-7).**

Linings are used as reinforcement materials in a wide variety of leather goods. The uses of linings in leather goods are: (i) to mask the rough surface of split leather components, (ii) to cover the defects of flesh side of the leather components, (iii) to add sufficient

strength to the components, (iv) to match the colour of the articles and (iv) to improve the elegant look of the articles. Lining is done usually with fabrics, leathers and synthetics.

### **Fabric Linings:**

Cotton and silk are generally used as linings in leather goods. Drill and casement linings are used as linings in heavy and luggage leather goods. Taffeta, crape, satin, and moiré silk linings are used as linings in small, medium and sophisticated leather goods. Velvet linings are used in jewel boxes, camera cases and attaché cases.

### **Leather Linings:**

Suedes, splits and skivers are used as linings in leather goods making. These linings give more strength, durability and luxury look to the products. Suede linings are used in sophisticated leather goods like brief cases, attaché cases, jewel boxes, camera cases etc. Split linings are used in heavy and luggage goods. Skiver linings are used in small leather goods.

### **Synthetic Linings:**

Plastic, rexene, nylon and flocked fabric (imitation suede) linings are used in certain types of leather goods. Flocked fabric or imitation suede lining is used as a substitute for suede leather lining in a variety of articles. Plastic or rexene linings are used as linings in articles where water-proofing is necessary for example shaving kit, cosmetic box, water bottle covers, etc.

### **3. Adhesives:**

An adhesive is a substance, which can hold materials together by surface attachment. The bodies held together by adhesive are known as adherents while the process of holding one adherent to another by adhesive is called 'bonding' and the final assembly of two adherents and the adhesive is called bond or joint. The requirements of an adhesive are: it should wet and adhere to the surface to be bonded and the dry film should have high cohesive strength. There are two main types of adhesion- Specific and mechanical. Specific adhesive is related to molecular attraction and polarity and is usually the determining factor governing the selection of an adhesive for surfaces such as metal and glass. Mechanical adhesion is most evident in bonding of papers, textiles, leathers, etc. where the adhesive penetrates the interstices of the material and blocks itself into a fibrous structure. Commonly used adhesives in leather goods making are natural rubber adhesive and synthetic rubber adhesive (**Fig.3-7**).





**Fig.3-7: Linings and adhesive**

**Basic steps in the adhesive bonding or sealing process:**

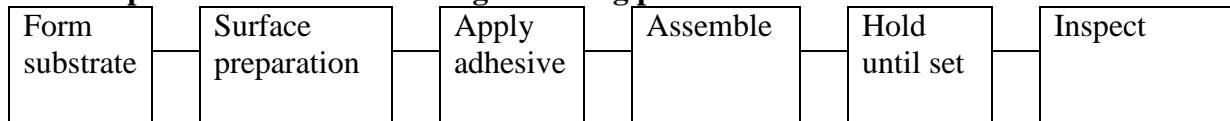

**Advantages of adhesive:**

- i. It can be applied to the surface of any materials
- ii. It does not require high heat for bonding
- iii. It facilitates the surface to join easily and rapidly
- iv. Its application is simple and
- v. It gives smoother surface

**Limitations:**

- i. Most of the adhesives are organic materials and as such they cannot be used at high temperatures.
- ii. The bonding strength decreases as the temperature increases
- iii. Specific adhesive is required for specific jobs and hence selection of suitable adhesive is necessary
- iv. Adhesives take time for curing and setting.
- v. Adhesives are generally susceptible to high humidity.
- vi. Adhesives provide perfect bonding only on plain and clean surfaces.
- vii. Adhesive strength is generally lower than other methods of joining like riveting.

**Quality of Adhesive:**

Quality of adhesive is judged by (a) degree of tackiness (b) rapidity of bonding (c) strength of bonding effect after drying and (d) durability.



**Selection of Adhesive:**

- i. Depending upon the type of materials, specific adhesive is needed to achieve good bonding effect.
- ii. Depending upon the application of adhesive either by brush or by any other means, the viscosity and solvent system must be taken into consideration.
- iii. The solvent in the adhesive must evaporate quickly for giving rapid tack development.
- iv. Tack retention must remain as long as possible for perfect bonding.
- v. While choosing the adhesive to give high bonding strength, the performance of the adhesive and other conditions like heat, water and flexibility must be taken into consideration.
- vi. The adhesive should give trouble free performance both during application and in service.

**Various types of adhesives:****Natural adhesives:****I) Vegetable origin:**

These adhesives are soluble or dispersible in water and are produced or extracted from natural sources, e.g. starch, soybean glue and casein glue. They are used for common adhesive jobs.

**II) Animal origin:**

These adhesives are often called hot glue made of hides, bones and other parts of cattle. These are applied hot to the pieces to be glued and as the adhesives cool and lose moisture, they become quite hard. It is low moisture resistance and the strength of bonding deteriorates. They are used in furniture, card box industries, etc.

**III) Elastomeric resins:**

Natural synthetic rubber based adhesives usually have excellent peel strength but low shear strength. Their resiliency provides good fatigue and impact properties. Temperature resistance is generally limited to 150 to 200 F degrees e.g. reclaimed rubber, natural rubber, neoprene rubber, nitrile rubber, etc. They are mainly used in automobile, metal, glass, and leather industries.

**IV) Thermoplastic synthetic resins:**

Thermoplastic adhesives represent a class of adhesive that can set without chemical reaction. They can be repeatedly melted and solidified without great hindering their properties. They can be dissolved in solvent or suspended in water based emulsion. They harden either by evaporation of solvent or on cooling from a hot melt. e.g. cellulose nitrile, polyvinyl s (polyvinyl acetate and polyvinyl chloride), acrylics, etc. They are used in footwear, cloth, paper, glass, furniture and ceramic industries.

**V) Thermosetting synthetic resins:**

Thermosetting adhesives form three-dimensional compounds with cross-linked structure and possess great adhesive properties. The bond obtained with them is insoluble, infusible and possess good resistance towards moisture, heat, insects, fungi, etc. e.g. phenol-formaldehyde, urea-formaldehyde, resorcinol, epoxy compounds, etc. They are used in furniture, aircraft-building, glass, metal and ceramic industries.

#### 4. Threads:

To provide good sewing performance a thread must have consistent size, strength, stretch and needle heat resistance. The thread selected for sewing has to provide satisfactory appearance in the seam in both stitch formation and colour match. Sewing threads are made from two types of fibres - (1) natural fibres (cotton, silk and linen) and (2) synthetic fibres: (nylon, polyester, rayon etc). Natural fibres provide best sewing performance while synthetic fibres provide best seaming performance. Cotton thread is vulnerable to abrasion while synthetic thread provides excellent seam strength, resistance to abrasion and wears (Fig.3-8).



**Fig.3-8: Cotton and synthetic threads**

#### **Special features of Polyester cotton Threads:**

- i. Improved sewing performance because it is less harsh.
- ii. Cotton rap acts as insulation against needle heat.
- iii. Gives extra seam grip.
- iv. Fills the needle hole completely and
- v. Prevents leathers being cut by the hard synthetic core.

#### **Special features of Nylon cotton Threads:**

- i. High strength and durability.
- ii. Excellent fineness/strength ratio.
- iii. Higher abrasion resistance.
- iv. Improved sewability.
- v. Better seam performance.
- vi. Rot-proof and immune to attack by mildew, fungus etc. and
- vii. Minimum wear of machine parts because of superior lubrication.

**Types of threads used in leather goods making (Table-3-1):**

<b>FIBRE</b>	<b>NO.</b>	<b>RANGE OF LEATHER GOODS</b>
Nylon	120,90	Small Leather Goods
Nylon	60,40,30,	Medium Leather Goods
Nylon	20,15,10	Heavy and Luggage goods
Polyester or Nylon Cotton	75	Small Leather Goods
Polyester or Nylon Cotton	50	Medium Leather Goods
Polyester or Nylon Cotton	35,25,15	Heavy and Luggage goods
Cotton	30,25,20	Small Leather Goods and Medium Leather Goods
Cotton	10	Heavy and Luggage goods

**Table3-1: Types of threads and its uses in leather goods making**

**5. Needles:**

Sewing of leather components and finished products are carried out by sewing machine, which is fitted with a sewing needle. The thick or top portion of the needle is rounded on one side and flat on the reverse side with the needle size usually etched into the rounded part. The thin or lower portion of the needle has a groove extending along the shaft from the rounded part to the eye. When a needle is inserted into the machine, the rounded side should face the direction from which the needle is threaded. For example, if the needle is threaded from the front to the back. The rounded side should face front. This positions the groove towards the thread, permitting it to guide thread as it feeds through the needle. There are three types of needles, which are commonly used for stitching. They are wedge point or leather point needle, ballpoint needle and regular sharp point needle. A leather point needle or wedge point needle is designed for stitching leathers. The wedge point makes a clear-cut in the leather, resulting in uniform stitches. The slightly rounded ballpoint needle is used for all knit and elastic fabrics because it pushes between fabric yarns instead of piercing them. The regular sharp needle is ideal for all woven fabrics because it helps to produce even stitching with a minimum of fabric puckering (**Fig.3-9**).

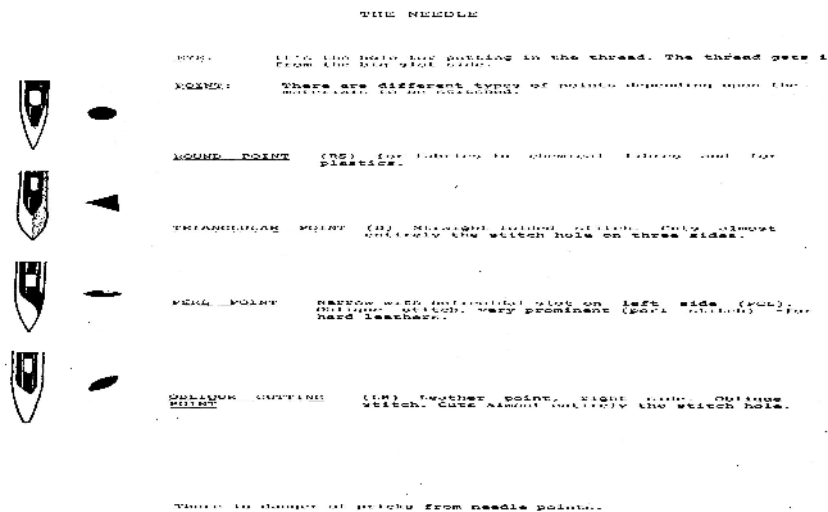

**Fig.3-9: Types of needle-points**

Sewing machine needle is numbered in metric number (Nm). This numbering corresponds to the diameter of the needle measured halfway up the needle and expressed in hundredths of millimetre. For example, for a diameter of 1,1 mm.=Nm. is 110. The needle numbers and its application are given below (**Table-2**).

Needle numbers	Application
No: 14 (90) No: 16 (100)	Light Leather Goods
No: 18 (110) No: 19 (120)	Medium Leather Goods
No: 21 (130) No: 23 (160)	Heavy Leather Goods

Table-2: Types of needles and its application

## 6. Other miscellaneous items:

### i) Reinforcements:

Reinforcements are the materials that are introduced in the articles to add substance, strength and shape. They are introduced in the articles in between the leather and lining materials. Reinforcements play a vital role in modern leather goods without which many of the designs would not be possible and most of the articles would have to be soft and shapeless. As reinforcement materials support the shape, strength, and thickness of the articles, they have to be cut accurately in the machine wherever possible... Roll directions have to be marked on boards, as this is very important to assist bending and prevent cracking of boards. In moulded, built-up and box work constructions, reinforcement materials are generally used. Some of the reinforcement materials which are commonly used are cartridge/drawing papers, mill boards, yellow straw boards, ply-wood/deal-woods, mild steel hoop iron frames, etc.

**ii) Cartridge / Drawing Papers:**

Cartridge papers or white drawing papers are used for pattern making process. It is also used as a lining reinforcement.

**(ii) Millboards:**

Millboards are used in a variety of works in leather goods making, in particular, for making patterns for the products. It has a smooth surface on one side and coarse surface on the other side. The smooth side provides uniform smooth surface to the leather components during assembling while the coarse side provides firm grip to the reinforcements. Mill boards are used as a reinforcement material in making moulded type of articles like, jewel box, penholder tumbler, pincushion, desk pad, letter paper and envelope case, visiting card case, etc. and also in heavy leather goods like document case, briefcase, suitcase etc.

**iii) Straw boards:**

Yellow straw boards are used as reinforcement material in making moulded type of articles viz. desk pad, pen and pencil tray, penholder, pin cushion, photo frame, etc.

**iv) Ply-wood/deal-wood:**

Ply-wood/deal-wood is very lightwood and hence they are suitable for making frames for box type goods viz. attaché cases, suitcases, jewel boxes, etc.

**v) M.S hoop iron frame:**

M.S. hoop iron frames are used as reinforcement material in heavy/luggage goods. They not only help to provide sufficient strength to the fittings but also prevent deformity of the products due to impact. M.S. hoop iron frames are used in document cases, medical representative bags, sports kit bags, suitcases, etc.

**vi) Foam rubber sheets:**

Polyurethane foam rubber sheets are used in a variety of leather goods where cushioning of the products is necessary. 2m x 1m x 3mm and 2m x 1m x 6mm foam rubber sheets are normally used in leather goods making.

**vii) Crepe rubber:**

White natural crepe rubber sheets are used to remove excess adhesive in the finished products. Crepe rubber sheets are also used for making rubber adhesives.

**viii) Piping wire:**

Plastic wires are used for piping in stitch and turn articles. Piping wire not only gives elegance to the product but also gives additional seam strength (**Fig.3-10**).

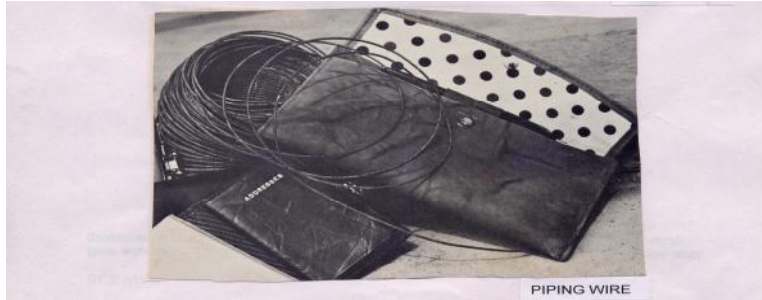

**Fig.3-10: Piping wire**

**ix) Pigments:**

Water-soluble pigments of different colours are used for staining the edges of the cut-edged articles and leather cut components before assembling process.

**x) Saddle soap:**

It is made of oil and wax. It is used to clean, polish and soften leather components.

**xi) Bee wax:**

Bee wax is used for making the raw edges smooth. It provides water resistance and glossiness to the stained edges by vigorous rubbing with a smooth piece of the cloth.

**xii) Silver marking pencil:**

Silver marking pencil is used to mark defects on leathers during assorting process. Silver marking pencil is also used to mark on leathers with patterns for cutting components to achieve the maximum cutting value. It is also used to mark on the components for fixing fittings with the help of patterns (**Fig.3-11**).

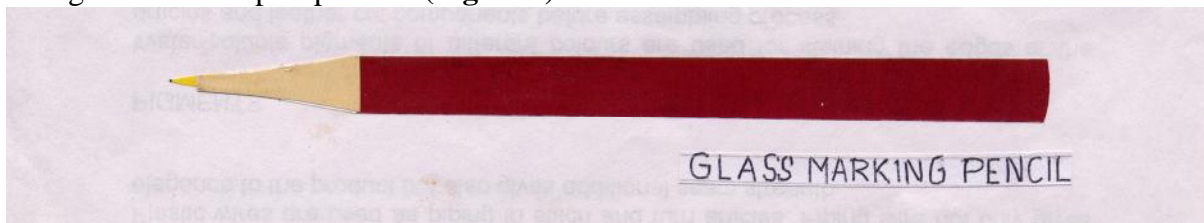

**Fig.3-11: Silver marking pencil**

**xiii) Double face adhesive tape:**

Double face adhesive tape is used to attach zips in leather goods because it enables easy and quick attachment of zips without causing any stains on the products. The attachment of zips with double face adhesive tape is preferred to the attachment of zips with rubber adhesive because rubber adhesive takes longer time for tack developing and setting and also causes stains on the products due to excess application (**Fig.3-12**).

**xiv) Brushes:**

Different types of brushes according to the requirements are used to apply adhesive on the components during assembling process. Adhesives are also applied by glue dispenser, which ensures tidy works (**Fig.3-12**).



**xv) Glue container:**

Small and big glue containers with vent are used during bench work assembling operations. These containers are preferred to tin containers, as they are very useful in using adhesives economically and also in preventing adhesives becoming solid due to evaporation (Fig. 3-12).

**xvi) Teflon/Plastic pieces:**

12 cm x 8 cm and 15 cm x 10 cm Teflon/plastic pieces are used for punching works during bench work assembling process (Fig.3-12).

**xvii) Abrasives:**

Abrasives with different grades are used for different types of works. Abrasives are mainly used to make the edges smooth of the cut edged articles before staining and wax polishing. Abrasives are also used for sharpening the knife.



Fig.3-12: Double face adhesive tape, brushes, glue containers and teflon/plastic p

# Chapter 4

## Tools

A tool is an extension of human hand. Tools are expensive and manufactured with high quality materials, properly machined, nicely finished and fitted with comfortable handles. Hand tools offer high degree of control and precision. Using proper tools for the proper jobs, a clean well-lighted working area, adequate instructions for performing jobs and safety precautions are the key factors for producing quality products. As tools play a vital role in the manufacturing of leather products, it is necessary to keep them in good working condition by storing them ready to hand as well as safe from damage. Tools are classified into: tools for pattern cutting, tools for leather goods fabricating, tools for leather crafting and tools for dual performance i.e. tools for leather goods fabricating and repairs and maintenance of equipments and machinery.

### TOOLS FOR PATTERN CUTTING

#### 1. Try squares:

Squares are simple tools that consist of a handle and calibrated blade set at 90 degrees to each other. Try squares are used to draw lines at right angles to surfaces. When adjacent surfaces form a 90-degree or right angle, they are said to be square to each other. This is very important to the artisan as most components are assembled square to each other. Try squares of 30cm x 15cm and 45cm x 25 cm and 60cm x 30cm are used to measure, place and guide cutting of straight lines, mark and set up patterns and projects (**Fig.4-1**).



**Fig.4-1: Try square**

#### 2. Divider

A divider is used for making parallel lines and circles in pattern making process (**Fig. 4-2**).

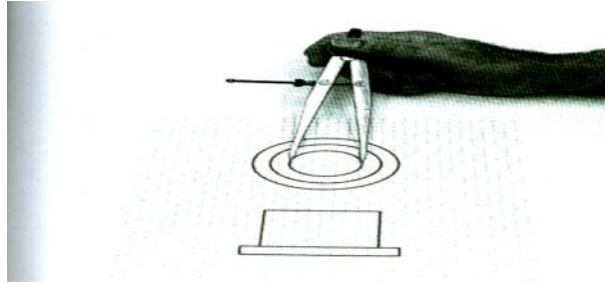

**Fig.4-2: Divider**

### **3. Measuring tape:**

A flexible measuring steel tape is available in different lengths. A 3'x3/4" (decimal/fractional) is a reasonable choice. The hook at the end of the tape should slide back and forth a distance equal to the thickness for accurate inside or outside measurements. Measuring tape is used to take measurements of the parts of the sample leather products, given for fabrication.

### **4. Utility knife:**

Utility knife is a precise cutting tool fitted with a retracting blade. It is used in pattern cutting process (**Fig.4-3**).



**Fig.4-3: Utility knife**

### **5. Stainless steel scale/ ruler:**

Stainless steel scale/ruler is used in pattern making process. The parts of the leather product are drawn first on a drawing paper with accurate measurements, using a ruler and then the measured parts are cut, using ruler and knife as paper patterns. It is also used as a cutting guide for cutting leather and lining components for making leather goods. 12" and 24" stainless steel scales are normally used (**Fig.4-4**).

## **TOOLS FOR LEATHER GOODS FABRICATING:**

### **1. Bevelled M.S. flat/stainless steel scale ruler:**

4'x1/4" mild steel bevelled flat or a stainless steel meter scale is used to level leather hides or sides before cutting them into straps. These straps are used as belt straps, shoulder bag straps and piping straps (**Fig.4-4**).

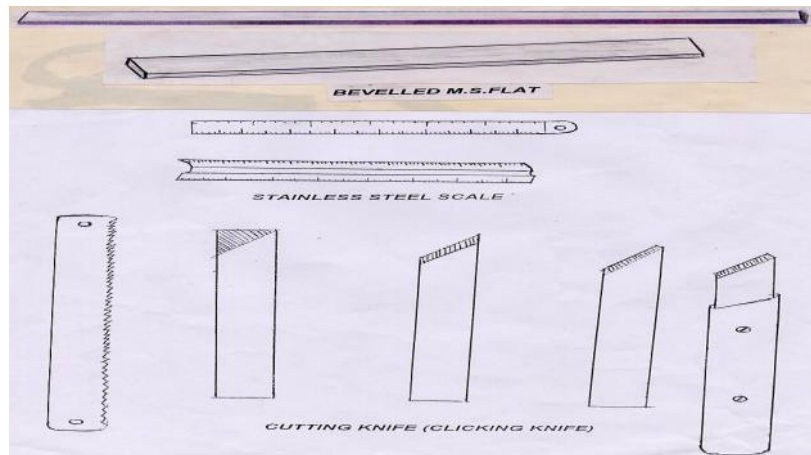

**Fig.4-4: M.S. flat, stainless steel scale and cutting knife**

### **2. Cutting/clicking knife:**

Cutting knife/clicking knife consists of a steel blade mounted in a handle to improve grip and control while cutting. It is made of 1'x1/2" H.S.S power hacksaw blade. The teeth of the blade are removed by grinding it in the grinding machine. The blade is then cut into two equal parts. One end of the knife is tapered to a suitable cutting angle and sharpened well in the grinding machine till a fine cutting edge is obtained. The knife is then sharpened again in an oilstone for removing the burr. Cutting knife/clicking knife is used for a variety of jobs in leather products fabricating viz. cutting paper patterns, leather components, lining components, foam and reinforcement materials (**Fig.4-4**).

### **3. Paring/skiving knife:**

Paring knife/skiving knife is made of H.S.S power hacksaw blade of size 1'x1". The teeth of the blade are removed first in the grinding machine. The blade is then cut into two equal parts. One end of the blade is tapered to a suitable skiving angle in the grinding machine. The knife is then sharpened well on one face till a skiving edge is obtained. The knife is again sharpened in an oilstone to remove the burr. Skiving knife is an important tool, which is used to skive the edges of the leather component for folding. The flat face of the knife enables to move through the fibres of leather components easily without causing damage to the components. The skiving face of the knife enables to skive smoothly to required thickness for perfect edge folding of leather components. Straightedge and curved edge skiving tools are used to skive leather components (**Fig.4-5**).



**Fig.4-5: Hand skiving tools**

#### **4. Hammer:**

The common hammer has a foot-long hickory handle, secured through the eye of the head with wooden wedge and a pair of iron ones. The hammer will do all the pounding, pulling, tapping, knocking, etc. Since hammer is no less extension of the arm than any other tool, it is important to have one that is suited to size and is comfortable to use. Steel hammer is used in assembling process for making leather goods. Light weight hammers 100gms and 200gms are used for light works and hammers of weight 300gms and 500gms are used for medium and heavy works. Hammers are used for punching holes, setting rivets and snaps (**Fig.4-6**).

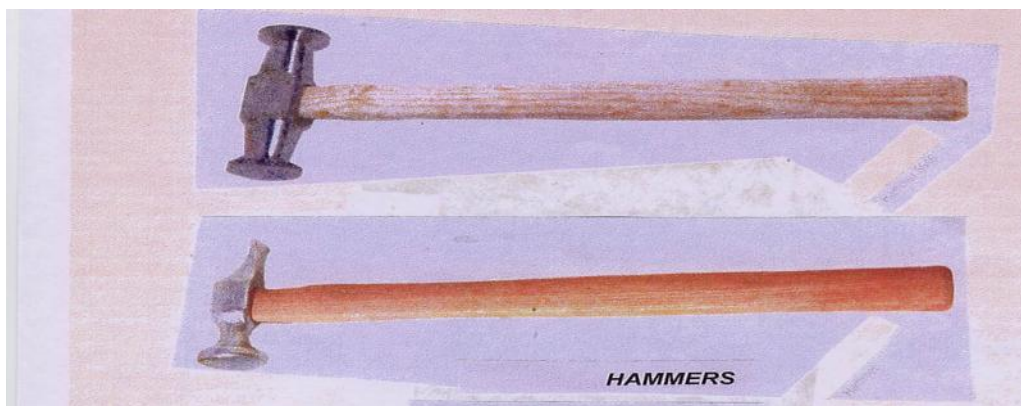
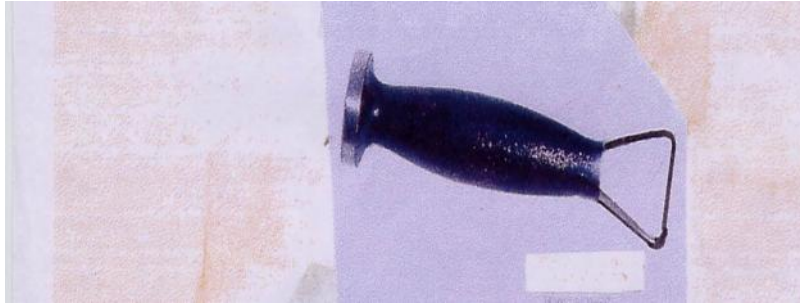

**Fig.4-6: Hammer**

#### **5. Hand stamper:**

Hand stamper is used in bench work operations. It is very convenient to use when compared to hammers. Hand stamper is used for punching holes, setting rivets and snaps and edge folding of glued components during assembling process (**Fig.4-7**).

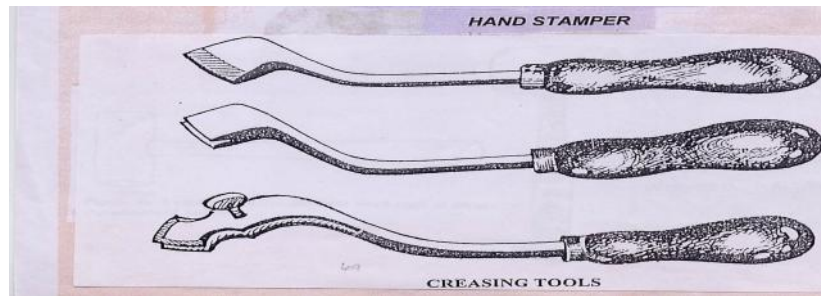



**Fig.4-7: Hand stamping tool**

### **6. Creasing tool:**

Creasing tool is used to crease edges of the leather components by heating. It is used for making distinct lines in cut-edged articles and crafted articles. viz. coin purses, wallets, key cases, belts, etc. It not only gives strength to the components by compressing the fibres but also gives decorative and aesthetic look. Different types of creasing tools are used for different types of works. Generally, single line creaser, double line creaser and adjustable creaser are used for making creases at the edges of the components of the products (Fig.4-8).



**Fig.4-8: Creasing tools**

### **7. Revolving punch:**

The revolving punch or rotary hole punch with four or six different size tubes is used for punching holes for lacing, riveting, eyeleting and snap setting in leather components (Fig.4-9).

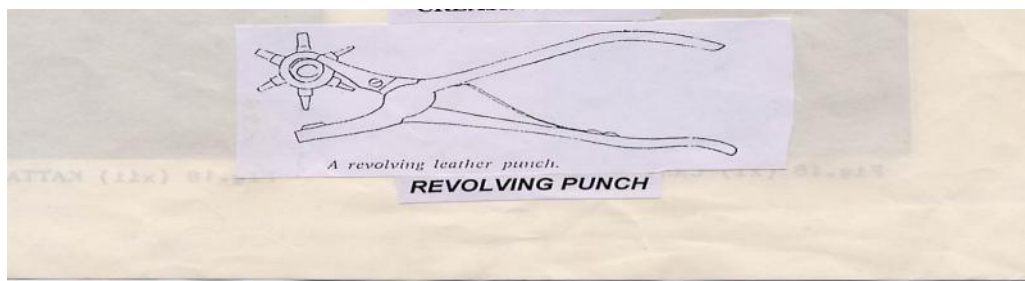

**Fig.4-9: Revolving punch**



## 8. Punch:

Punch or round drive punch is a cylindrical slotted punch made of tempered steel. Different sizes of punches 00, 0,1,2,3 and 4 are used for making different sizes of holes in leather components. These punches are used for fixing buttons, rivets, rivet buttons, eyelets, studs, etc. in leather goods. Oblong/crew punches are used for making holes in leather belts and hold all straps (Fig.4-10).

## 9. Scissors:

Scissors are used for cutting leather components, lining components, foam, reinforcements, etc. in leather products fabrication. Big scissor is used for cutting leathers, linings, etc. while small scissor is used for trimming excess thread after stitching. Pinking scissor is used for ornamental cuttings. It is very much used in garment industries (Fig.4-10).

## 10. Thread trimmer:

Thread trimmer is used to trim excess thread after stitching of the components or products in the sewing machine. It is also used in final finishing of the products to trim excess thread, left un-noticed (Fig.4-10).

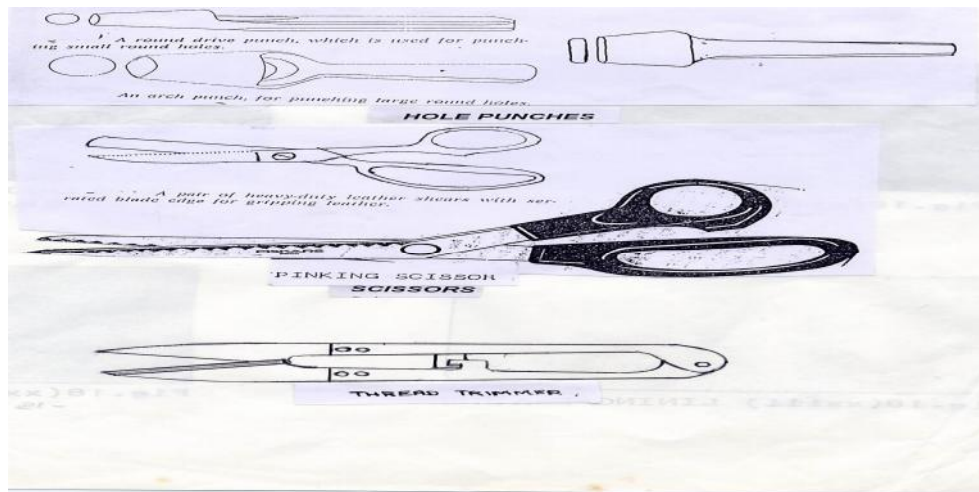

Fig.4-10: Hole-punches, ordinary scissor, pinking scissor and thread trimmer

## 11. Framing tools:

Framing tools are used for making framed purses and framed handbags (Fig.4-11).

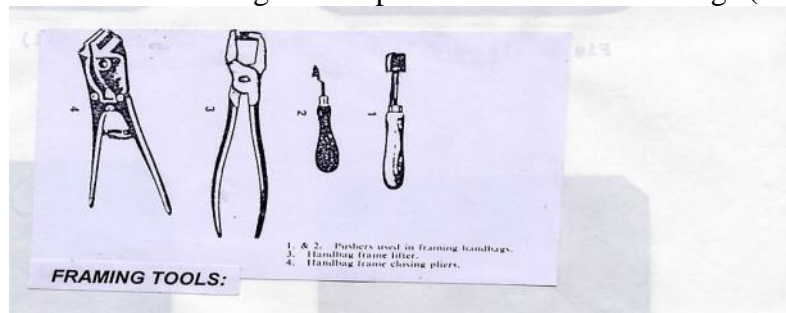

Fig.4-11: Framing tools

**i) Frame lifter:**

Frame lifter is used to open the slot of the frame so that the framing edge of the handbag can be pushed easily into the slot.

**ii) Leather pushing tool:**

Leather-pushing tool is used to push the framing edge of the handbag into the slot of the frame uniformly.

**iii) Frame- pressing tool:**

Frame-pressing tool is used to press the frame after the framing edge of the bag is pushed into the slot by the pushing tool. The pressing of the frame is done carefully and uniformly done by the frame-pressing tool for perfect framing of the bag. The pressing tool is very useful for closing the frame without causing any damage to the framed bags.

**12. Button fitting/snap setting tool:**

Button fitting/snap setting tool is a set of cylindrical knurling tool. One tool has a provision for fixing cap spring into the cap and the other has a provision for fixing snap rivet into the snap stud. This tool is extensively used for buttoning in leather products for various functions. 3/2 and 3/3 button fitting tools are generally used in light and a medium leather products while 7/7 button fitting tool is used in heavier leather products (Fig.4-12).



**Fig.4-12: Button fitting tool**

**13. Eyeletting tool:**

Eyeletting tool is a cylindrical knurling tool. One end of the tool has conical with sharp teeth and the other end has flat smooth surface. It is used to rivet eyelets in key cases, belts, stretch bags, etc. Grommet eyelet setter can also be used to set eyelets (Fig.4-13).

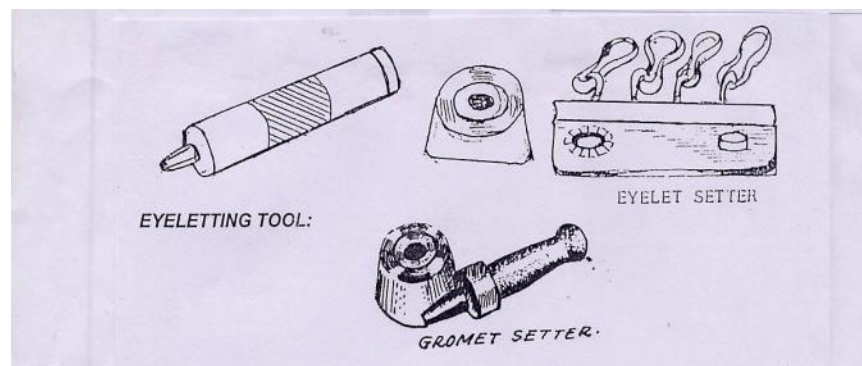

**Fig.4-13: Eyeletting tool**

#### 14. Riveting tool:

Riveting tool is a cylindrical knurling rod. One end of the rod has slightly concaved smooth surface and the other end has flat smooth surface. It is used for riveting rivet buttons in leather products (**Fig.4-14**).

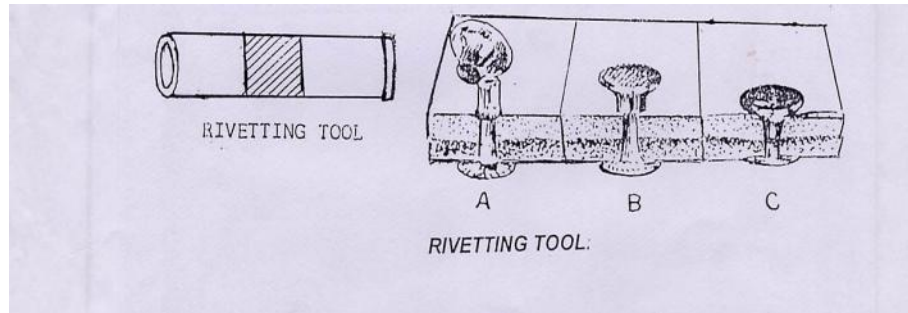

**Fig.4-14: Riveting tool**

#### 15. Smooth rolling wheel:

Smooth rolling wheel is used to remove lumps and air bubbles while joining the components with adhesive. It is also used for flattening laced edges in leather-crafted goods (**Fig.4-15**).

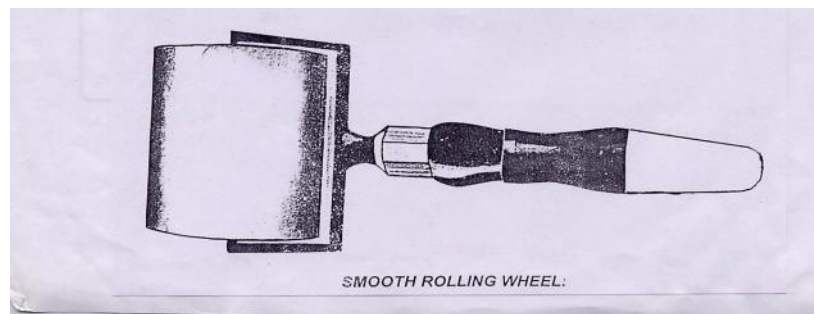

**Fig.4-15: Smooth rolling wheel**

#### 16. Circular slicker:

Circular slicker is a circular tool with a smooth groove at the centre. It is used to burnish the edges of the leather strap by rubbing vigorously with the groove (**Fig.4-16**).

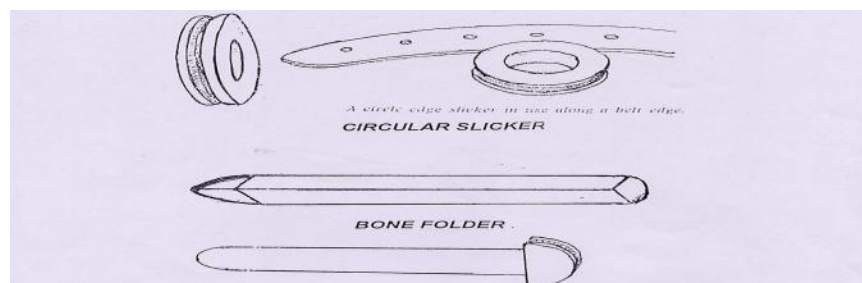

**Fig.4-16: Circular slicker and bone folders**

**17. Bone folder:**

Bone folder is made of buffalo horns. One end of the folder is filed off to a pointed edge and the other end is rounded off to a smooth edge. It is also made from plastic. It is an inexpensive folder and edge crasser. It is used for folding, lining, piping and creasing during assembling process. American folding tool is also used for folding the glued components (Fig.4-16).

**18. Dauber:**

Dauber is made of a cotton or sponge ball with an iron wire handle. The absorbent ball helps to spread the dye at the cut edges of the leather components (Fig.4-17).

**19. Awl:**

Awl is a tempered sharp steel needle with a wooden handle. It helps to make marks during pattern cutting process and also during assembling process where leather components are marked and fitted with fittings (Fig.4-17).

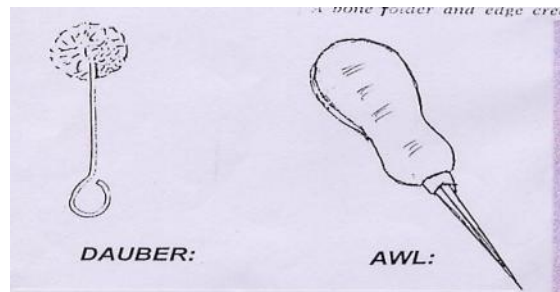

**Fig.4-17): Dauber and awl**

**20. Thread trimming tool:**

Thread trimming tool is a very important tool used to fuse excess thread after stitching. Since leather goods are stitched with synthetic threads, it is necessary to use thread-burning tool to fuse the excess thread after stitching. This enhances stitch appearance on the products (Fig.4-18).

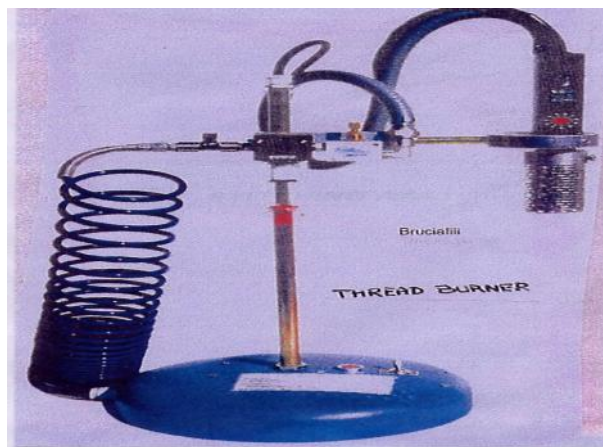

**Fig.4-18: Thread burning tool**

## 21. Stitching awl:

Stitching awl is a tempered steel needle. One end of it is flattened with a groove to pull the thread. The flattened head is made very sharp so that it can pierce into the fibrous leather components easily. It is generally known as cobbler's needle. It is used in leather goods making for stitching handles and also for joining components where machine stitching is not possible (**Fig.4-19**).



**Fig.4-19: Stitching awl**

## LEATHER CRAFTING TOOLS:

Leather crafting tools are used in leather craft works to give different effects on moistened vegetable tanned leathers. Commonly used carving tools in leather craft works are:

### 1. Tracer stippler:

Tracer stippler is a cylindrical tool, tapered at both ends. One end resembles blunt pencil point and the tip of it is rounded and buffed to prevent leather being cut while tracing designs. This end is used for tracing designs on the moist surface of the leather from tracing paper with designs. The other blunt end, which resembles very closely the tracing end, leaves a distinct mark when pressed firmly on moistened leather (**Fig.4-20**).

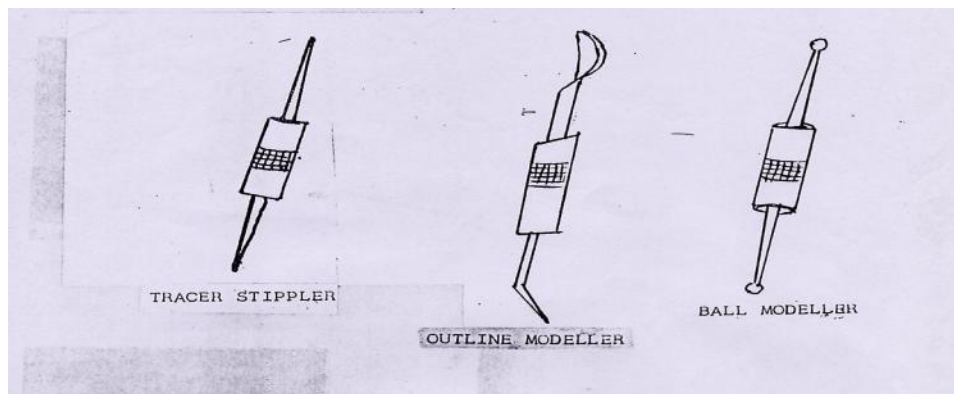

**Fig.4-20: Carving tools**

### 2. Outline modeller:

In outline modeller, one end of it is tapered and bent. The tip is blunt and smooth. This end is called out-liner, which helps to trace designs on leather. The other end of the tool

is a modeller. It is spoon shaped and is used for tooling carved lines. Both the outliner and modeller are very smooth and highly polished to permit an easy gliding movement on the moist leather (**Fig.4-20**).

### 3. Ball modelling tool:

Ball modelling tool has smooth polished ball ends. It is used to compress small areas of leather not easily accessible with other modelling tools. It is also used for embossing (**Fig.4-20**).

### 4. Swivel knife:

Swivel knife is a cylindrical tool. One end of the swivel knife has a chisel end. The top of the knife is fitted with a U shaped handle. The stem of the knife can be twisted to any direction. It is used to make decorative cuts on moist leather (**Fig.4-21**).

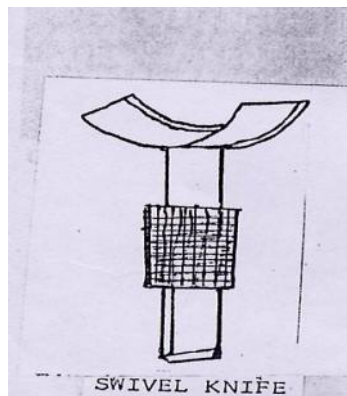

**Fig.4-21: Swivel knife**

### 5. Mallet:

Mallet is made of rawhide leather with a wooden handle. It is used as a tapping mallet for light chisel work or for gently knocking pieces of finished components during assembly. Carving rawhide mallet is used for light works and tooling works in leather craft articles (**Fig.4-22**).

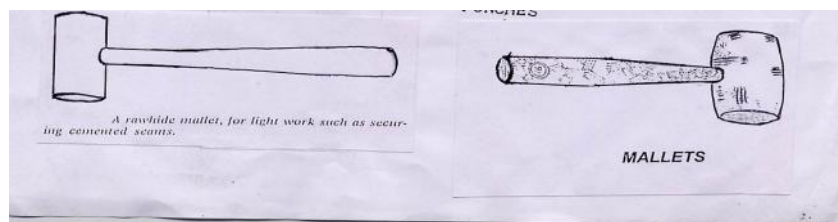

**Fig.4-22: Rawhide mallets**

### 6. Design punches:

Design punches are knurling cylindrical punches. One end of the punch is flat and the other end is engraved with a variety of floral designs. These punches are made in a



variety of designs and shape viz square, oval, round, elliptical, star, diamond, and other geometrical shapes, etc. They provide decorative effects on moistened leather (**Fig.4-23**).

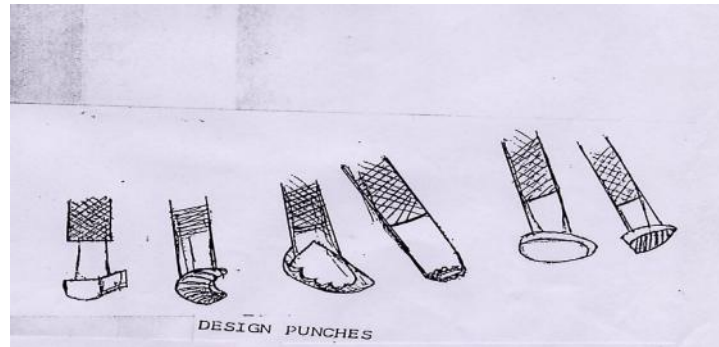

**Fig.4-23: Design punches**

### **7. Spacing wheel:**

Spacing wheel is used as a marking tool for lacing in crafted articles. viz. coin purses, key cases, wallets, spectacle cases, ladies bags, etc.(**Fig.4-24**).

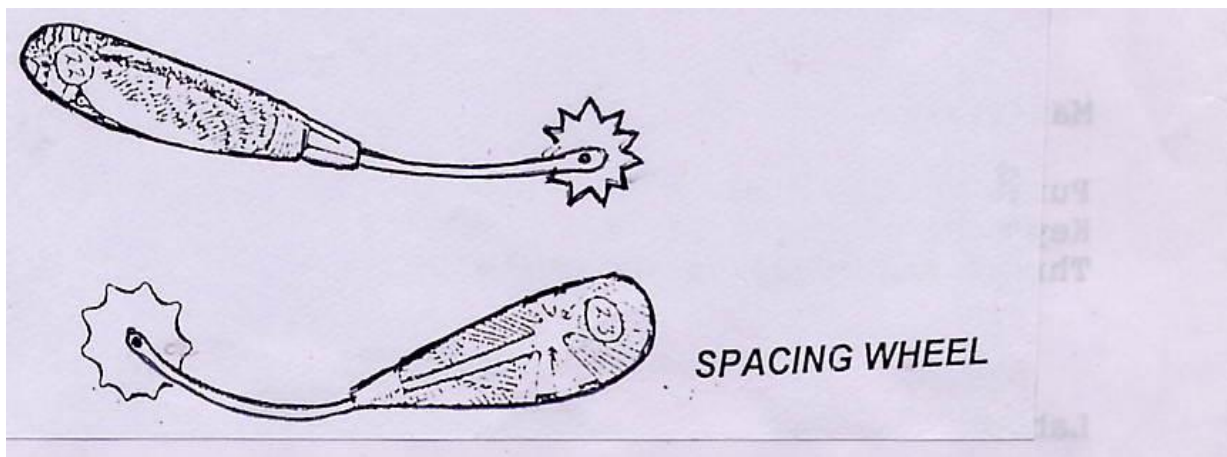

**Fig.4-24: Spacing wheels**

### **8. Lacing pony:**

Lacing pony is made of smooth hard wood with flexible gap at the center to hold components. The firm holding of components for sewing and lacing is done by a wing nut adjustment (**Fig.4-25**).



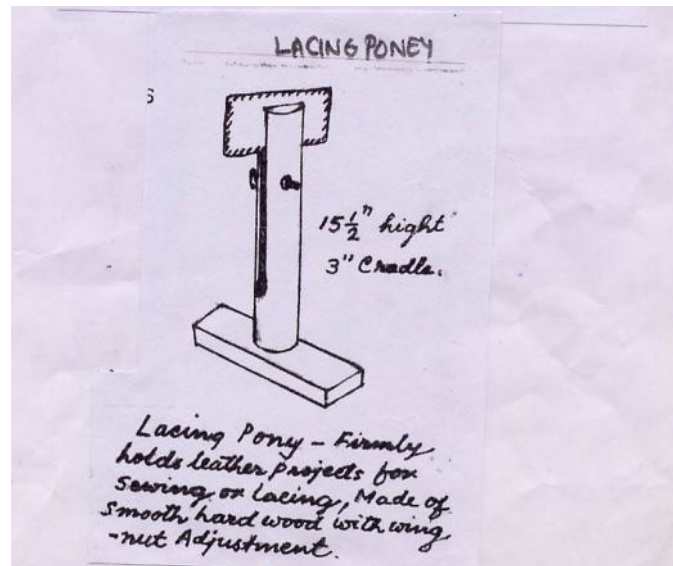

Fig.4-25: Lacing pony

### 9. Heat burnishing tool:

Heat burnishing tool is used to get a fascinating variety of effects by following the outline of the floral designs drawn on the moistened vegetable tanned leather. The following of the outline is used by the burning brass pencil tip or brass all purpose tip. The burning pencil is allowed to reach the maximum heating capacity before starting to burn the leather. For best results, the pencil is moved very slowly. This type of tooling work is called pokerwork (Fig.4-26).

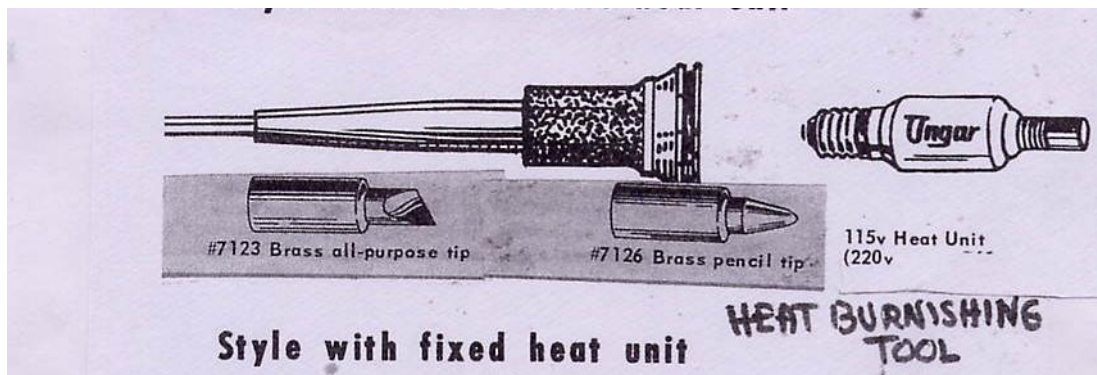

Fig.4-26: Heat burning tool

## TOOLS FOR LEATHER GOODS FABRICATING AND REPAIRS AND MAINTENANC OF EQUIPMENTS AND MACHINERY

### 1. Screwdrivers:

Screwdrivers are used to drive screws. The two most commonly used types of screws are slotted and Phillips head. Slotted screws are driven with standard screwdriver which is fitted with screwdriver-blade to fit screw slots closely to avoid slipping and screw-head

damage. Phillips head screws are driven by Phillips screwdrivers. Phillips screwdrivers are made in several numbered sizes, including No.1 and No.2. The lower numbered screwdrivers are designed to be used with small screws, while the higher-numbered ones are used for larger screws. Matching screwdrivers to screw-head sizes helps to prevent damaging screw heads. Screwdrivers are available in lengths ranging from 2 to 18 inches. Short screwdrivers are used with small screws or where working space is limited. Long screwdrivers are used with large screws or when screws are difficult to drive. Additional length adds leverage to drive screws easier. There are a number of other patented screw-driving systems viz. Reed & Prince head, Torx drive, Allen head, Clutch head, etc. for specific works. Suitable screwdrivers of different sizes are used for fixing fittings in leather goods and other machine repair works (Fig.4-27).

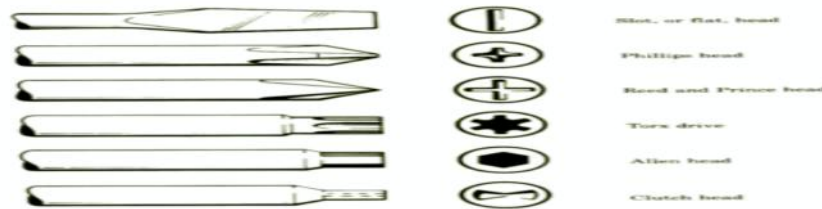

**Fig.4-27: Screwdrivers**

## 2. Wrenches:

The most commonly used wrenches for various repairs and maintenance works are open-end wrenches, box-end wrenches and adjustable open-end wrenches. Open-end wrenches are made of chrome-vanadium steel and are machined to accurate tolerances for a proper fit. They are used to tighten or loose bolts and nuts. Box-end wrenches surround a nut or bolt and apply pressure to all its corners. They are less likely to ruin a fastener than an open-end wrench, which bears on only two corners. Adjustable open-end wrench is a general-purpose tool and it will fit nuts and bolts up to the maximum opening of its jaws (Fig.4-28).



**Fig.4-28: Wrenches**

## 3. Portable-electric hand drill:

Portable electric hand drills are the most commonly used power tools. Variable speed and reversible drills allow the tool to be used for driving and removing screws and other low-speed jobs. A power drill is a versatile tool that can drill holes in metal, wood, plastics, etc. and can take dozens of accessories for sanding, grinding, shaping, stripping, buffing, etc. It is easier to hold steady and it operates more rapidly. It is used for a wide range of works in leather goods manufacturing (Fig.4-29).



**Fig.4-29: Portable electric hand drill**

#### 4. Pliers:

Three types of pliers viz. nose pliers, diagonal cutting pliers and lineman's pliers are very useful in a leather products manufacturing workshop for cutting and bending, pulling small fittings and holding metal fittings that are to be filed or hammered. Nose pliers are used for cutting and bending thin wires and small fittings. Diagonal cutting pliers are sometimes called as wire cutters. It has scooped jaws, which make them ideal for extracting small nails, or damaged fittings. Lineman's pliers are sometimes called engineer's pliers. They are very useful for bending, gripping and manipulating sheet, metal and wire. Their wide, heavy, checked jaws and long handles provide leverage and nonslip hold necessary to turn the head of a bolt, the nut or stubborn screw whose slot is too chewed up to be removed with a screwdriver. These pliers are used in fabricating leather goods, repair works and maintenance of machinery (**Fig 4-30**).



**Fig.4-30: Linesman's plier      Diagonal cutting plier      Nose plier**

#### 5. Pincer:

Pincer pulls out nails that a claw hammer cannot (for example a wire nail without head). It is used for short pulls. The fine claw at the end of pincer handle slips well into the well-driven nails or rivets **Fig.4-31**).



**Fig.4-31: Pincer**

#### 6. Bench grinder:

Bench grinder has two grinding wheels. One is coarse and the other is fine. The grinding wheels are provided with guards and tool rest. The tool rest must be 3mm away from the wheel at the required angle. This prevents the tool from being dragged into the wheel. A bowl of cold water is kept by the side of the machine so that cooling of the work can be done periodically. Bench grinder is used to sharpen clicking and skiving knives. While sharpening the knife, the following steps are to be followed:

- i. adjust the angle of the knife to be ground,
- ii. use the hand to hold the knife steady while moving it across the grinding wheel from side to side and
- iii. keep the surface

being ground as cool as possible by dipping the knife in water bath. When the bevel has been removed, the knife is ready for whetting (**Fig.4-32**).



**Fig.4-32: Bench grinder**

### **7. Oil stone:**

A sharpening oilstone consists of thousands of tiny, harder than steel sharp-edged points with spaces in between. As the knife is pushed over the stone under pressure, these points grind off particles of steel. On the coarse side of the stone, the points are relatively large and far apart. The initial grinding removes metal rapidly but leaves the surface, and more particularly the edge rough and ragged. At this stage, the knife may feel sharp and indeed for a time may cut better than it did before. However, such an edge produces a cut that is more chewed than sliced and will soon break down again. It is the job of the fine side of the stone to grind away enough more metal to eliminate scratches and ridges from the bevel and to cut down the ragged metal along the cutting edge. Sharpening consists of three basic operations: 1) coarse grinding to remove any nicks and to reshape the bevel; 2) fine grinding to smooth and bring the bevel to a sharp edge; and 3) honing to refine the edge. Oilstones are used to sharpen cutting and skiving knives in fabricating leather goods (**Fig. 4-33**)



**Fig.4-33: Oilstone**

### **8. Oilcan:**

Oilcan is used to lubricate various leather goods tools, equipments and machines with suitable machine oils (**Fig.4-34**).



**Fig.4-34: Oilcan**

# Chapter 5

## Leather Goods Machinery

Most of the leather goods units, which are on small-scale levels, are manufacturing leather goods using only industrial sewing machines. The other unit operations like cutting, skiving, creasing, punching, riveting, etc. are done manually for the fabrication of leather goods. So the quality of the products cannot be assured as stage wise operations up to sewing are done by hand. Nowadays, most of the units use semi-automatic and automatic machines for the production of leather goods. These machines not only help to produce quality products but also help to increase the volume of production. Imported sophisticated machines are used by big and medium scale industries while indigenous manual machines are used by small-scale industries. In case of sewing machines, both indigenous and imported flat-bed sewing machines are used by all leather goods industries. The description and functions of the various machines used in the manufacture of leather goods are detailed below:

### ELECTRICAL AND ELECTRONIC IMPORTED LEATHERGOODS MACHINES:

#### 1. Hydraulic clicking press:

Hydraulic clicking press works on vacuum pressure. It consists of hydraulic drive and press tool namely die and punch. The hydraulic drive consists of a double acting hydraulic cylinder in which the piston moves up and down. The piston is connected to the ram through the piston rod. The ram slides vertically. The punch is fitted at the bottom of the ram (Fig.5-1).

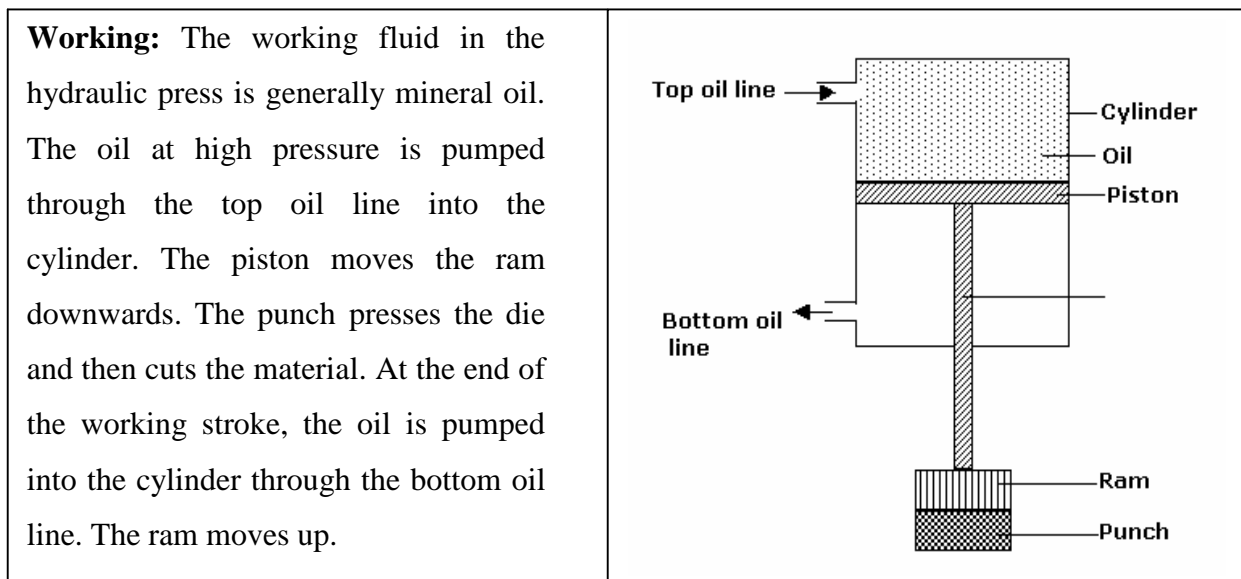

Fig.5-1 Principle of working



**Advantages:**

- i. The hydraulic press is used when a very high pressure is required on the ram.
- ii. The pressure on the ram can be easily controlled by means of hydraulic valves. Further, stroke length can be also adjusted.
- iii. Hydraulic drive gives a smooth and noiseless operation.

Hydraulic clicking press is extensively used for producing leather products in huge quantities. It is used to click leathers, linings, foam and reinforcements with clicking dies for manufacturing leather goods (Fig.5-2).

**Specifications:**

- a. Maximum cutting Power - 16-25 tones.
- b. Maximum Stroke - 90mm.
- c. Cutting Table width – 800mm x 400mm / 1000mm x 500mm.
- d. Arm width - 300mm to 500mm.

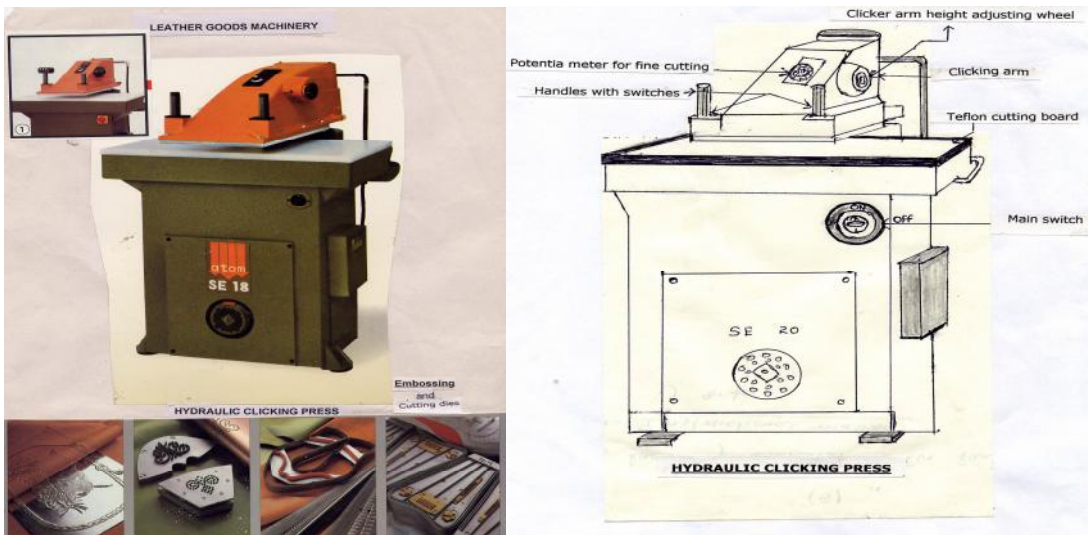

**Fig.5-2 Hydraulic clicking press**

**Parts and functions (Table-1):**

Parts	Functions:
Main switch	To supply electrical power to the machine
Clicking arm height adjustment wheel	To adjust the height between swing arm plate and die
Clicking arm	To click components
Potentiometer	To click different thickness of leathers
Handles	To move and press clicking arm for clicking components
Safety handle switches	To provide safety while clicking
Teflon cutting board	To take the pressure of cutting depth while clicking
Digital display	To display the number of components clicked

**Table-1 Hydraulic clicking press – Parts and its functions**

**Operations:**

The assorted leathers marked with defects and parts of the product are placed one by one on the cutting bed. The most important parts of the product, which are visible, are clicked first with the dies. The less important parts like gusset handle, handle bit, inner pockets, etc. of the product, which are not visible, are clicked next with the dies. The height between the swing arm bottom plate and the die is adjusted properly before clicking. Suitable dies are placed over the leather and the components are clicked by pressing the handle switches. The handle switches otherwise called safety switches can press the arm for clicking only if both the switches are pressed. Number of components clicked can be noted in the digital display. After clicking the components, the clicked components are checked for quality and then bundled neatly for next unit operation. The scrap pieces are put in the scrap box.

**Caution:**

- i. The machine must be switched off when not in use.
- ii. The height adjustment between the bottom plate and the die must be properly done otherwise it will damage the materials and the cutting bed.
- iii. Care must be taken to keep the dies safely otherwise its knife-edge may get damaged.
- iv. Care must be taken while placing the single knife-edge die on the leather for clicking components (knife-edge must be on the grain surface of the leather). If the placing is reversed, (knife-edge is facing the arm and the die head is facing the grain surface of the leather), the leather will get damaged.
- v. Avoid bunch clicking of components as it may damage the components.
- vi. Periodical planing of the cutting board must be done otherwise clicking of components will not be perfect. In case if cutting board is damaged due to constant clicking, it should be replaced with a new one.

**Advantages over hand cutting:**

- i. Speed of operation.
- ii. Accuracy and uniformity.
- iii. Productivity increase.
- iv. Negotiation of intricate patterns and least wastage.

**2. Strap cutting machine:**

Strap cutting machine is mainly used to cut straps for piping, belts and shoulder bag handles. Different types of strap cutting machines are used depending upon the needs of the Industry (**Fig.5-3**)

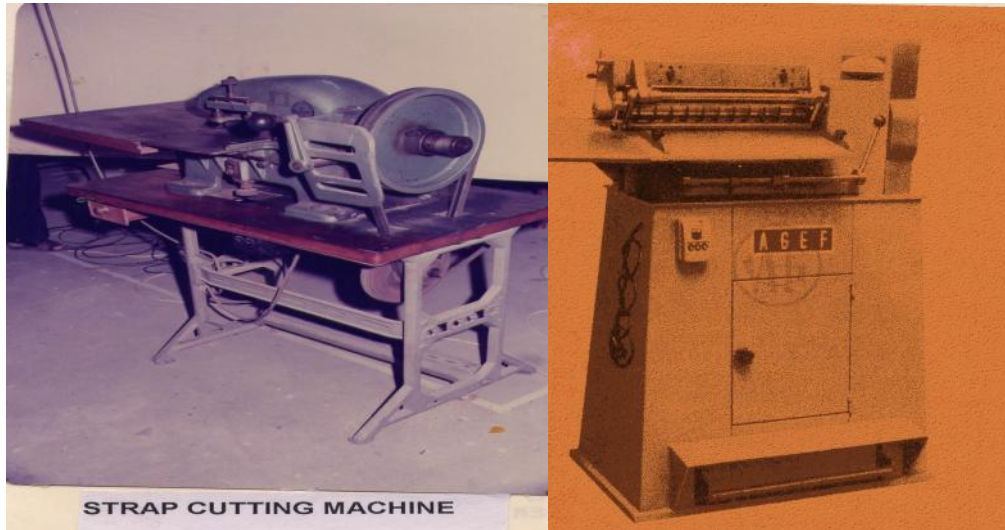

**Fig.5-3 Strap cutting machine**

**Parts and functions (Table-2):**

Parts	Functions
Main switch	To supply electrical power to the machine
Circular knives	To cut straps
Circular spacers	To adjust for required widths of the straps
Wipers	To prevent the cut straps rolling between the knives
Steel roller	To fix circular knives and spacers
Rubber feed roller	To feed leather for cutting straps
Guide	To feed the leather straight at 90 degree angles
Clutch handle	To make the steel roller and feed roller revolve
Scrap box	To collect scraps

**Table-2: Strap cutting machine – Parts and its functions**

**Operations:**

Necessary adjustments are made in the machine first for cutting straps to required widths. Before feeding the leathers for cutting straps, the edges of the leathers are made straight. The machine is switched on. The guide plate is adjusted to feed the leather straight. The handle is engaged by means of clutch and the leather is fed one by one touching the guide into the machine for cutting straps. After the straps are cut, they are inspected for quality and then bundled for next sequence of operation.



**Parts and functions (Table-3):**

<b>Parts</b>	<b>Functions</b>
Main switch	To supply electrical power to the machine
Control switches (on/off switches)	To start or stop the machine
Speed rate switches	To increase the speed rates for splitting
Partial splitting switch	To do partial splitting
Partial splitting length adjusting knob	To split the components partially to required length
Thickness indicating meter	To indicate splitting thickness
Thickness adjusting wheel	To adjust to required splitting thickness
Band knife	To split leather components
Grinding unit	To sharpen the blade for accuracy of splitting
Optical viewing system	To check the knife bevel whether it touches the splitting line
Upper driven guide roller	To split thickness from 0.5mm to 12 mm
Lower feed roller	Feed the components for splitting
Guide bar	To split thickness up to 0.2mm
Feed roller pressure adjusting knobs	To adjust the pressure of the feed roller for uniform splitting
Exhaust units	To collect scraps and dust during splitting
Pilot lamp	To provide sufficient light during splitting
Treadle	To pull out the stuck components between the rollers
Safety switch	To stop the machine if troubles develop suddenly

**Table-3: Splitting machine – Parts and its functions****Operations:**

The machine is switched on and the position of the knife is checked through the viewfinders whether the knife is touching the splitting line. If not, necessary adjustment is made to move the blade to coincide with the splitting line for uniform and accuracy of splitting. Before feeding the components for splitting, the blade is sharpened well by adjusting the grinding unit screws for uniform and perfect splitting. In case of bulk production, the sharpening of the knife is continued till the splitting of the components is over. The speed rate switches are switched on according to the speed of the production. The splitting thickness of the components is adjusted by thickness adjusting wheel, which can be seen from the digital display. Since, each part of the product needs different splitting thickness, it is necessary to adjust the thickness while splitting of the components. Upper guide roller is used to split to the thickness from 0.5mm to 12mm. In case, if splitting thickness of 0.2mm is needed, the guide bar is used. The working width for splitting ranges from 300mm to 500mm. Since the upper guide roller rotates simultaneously along with lower feed roller, the leather components can be easily fed for splitting. The components for splitting are fed one by one. Random checks for uniformity splitting thickness can be done by using thickness measuring equipment. In certain

components where partial splitting is required, the same is achieved by switching on the partial splitting switch and adjusting the partial splitting length adjusting knob. After splitting, the components of the products are inspected for the quality of splitting and then sent for next unit operation.

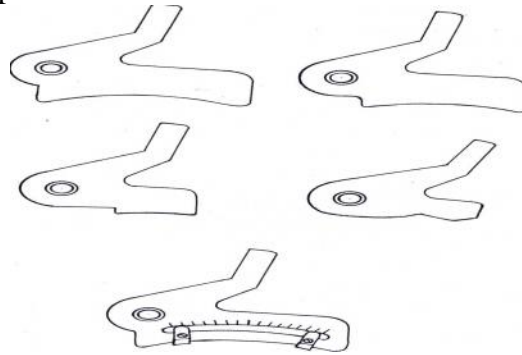

**Fig.5-6: Types of skiving foot**

### **Caution**

- i. Grinding stone must be dressed periodically for smooth sharpening of the knife.
- ii. After sharpening of knife, the burr must be removed by the dressing tool for perfect skiving.
- iii. Presser foot should not touch the feed roller while skiving, otherwise both presser foot and feed roller will get damaged.
- iv. Feed roller must be at a suitable distance from the knife while skiving. If feed roller is touching the knife, the feed roller will get damaged.
- v. For taper skiving both presser foot and the feed roller must be at the same angle. Otherwise both presser foot and feed roller will get damaged.
- vi. If the bell knife gets reduced and not fit for skiving, a new bell knife must be replaced.

### **5. Hydraulic embossing machine**

Hydraulic embossing machine works on hydraulic pressure. It is used to iron leather and lining components before assembling process. Leather and lining components need ironing to remove wrinkles due to handling at various unit operations. It is also used for design embossing on leather components by removing the plain plate and fixing the required design plate. Then embossing is done with suitable temperature and pressure to transfer the design **Fig.5-7).**



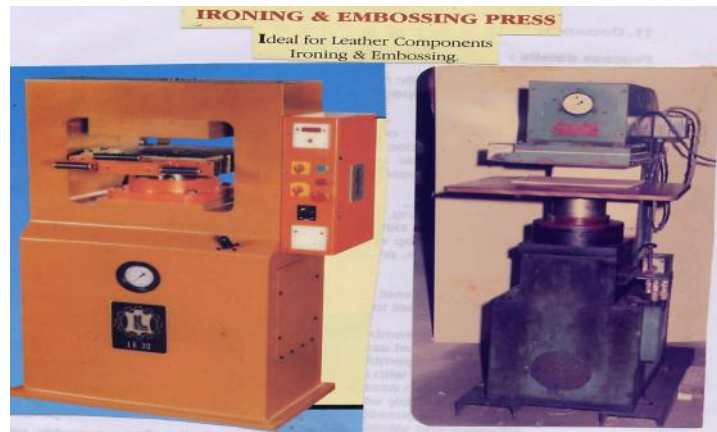

**Fig.5-7: Hydraulic embossing machine**

**Caution:**

- i. Before commencement of the splitting operation, the knife should be sharpened well for perfect and accuracy of splitting.
- ii. When grinding for sharpening of the blade is on, the machine should not be stopped because it will cause damage to the knife. After sharpening, the grinding stones must be pushed away from the blade by adjusting screws of the grinders.
- iii. Due to constant splitting, the thickness of the blade gets progressively reduced and unfit for splitting. This will affect the accuracy of splitting. In such case, the reduced blade must be replaced with a new one.
- iv. The Presser roller and feed roller must be cleaned well otherwise components may get stuck between the rollers.
- v. The machine should be cleaned well and lubricated after completion of the splitting operation. This will help the smooth running of the machine.

**4. Upper leather skiving machine:**

This machine is very important machine and is extensively used in leather goods manufacturing. It helps to reduce thickness of the leather components at the edges for easy folding. Only skilled persons can operate this machine as the quality of skiving depends on various adjustments and operation techniques. Different types of skiving viz. parallel skiving, channel skiving, taper skiving and fine edge skiving can be achieved using appropriate presser foot. The skiving can be done to a width of 3mm to 50 mm (Fig.5-5).



**Fig.5-5: Upper leather Skiving machine and its parts**

**1. Bell knife. 2. Presser foot. 2a. Presser foot holding spring. 3. Feed roller.  
4. Grinding wheel. 5. Guide. 5 a. Guide locking screw. 6. Thickness adjusting screw.  
7. Presser foot lifter. 8. Presser foot upper adjusting screw. 9. Locking screw.  
10. Grinding wheel forward and backward movement knob. 11. Bell knife  
movement knob. 12. Clutch for grinding. 13. Screw for up and down movement of  
the feed roller. 13a. Locking screw. 14. Screw for the lifting movement of the feed  
roller. 15. Tension adjusting screw. 16. Feed roller tension level. 17. Locking handle.**

**Parts and functions (Table-5):**

Parts	Functions
Main switch	To supply electrical power to the machine
Felt bad	To place the components for ironing
Top metal bed	To fix plain or design plate
Temperature device	To provide suitable temperature for ironing or embossing
Pressure gauge	To provide suitable pressure for ironing or embossing
Handle	To move the bottom plate for pressing the components
Oil sump	To push the oil at a high pressure through the oil line into the cylinder
Moveable piston	To move the bottom plate up when pressure is on and down when pressure is released

**Table-5: Hydraulic embossing machine – Parts and its functions****Operations:**

The required pressure and heat are first adjusted. The components are placed on the bed one by one and ironed. After ironing, the quality of ironing is checked and sent for next unit operation.

**Caution:**

- i. The oil leakage must be checked.
- ii. Recommended oil alone must be used.
- iii. The blockage of dust particles in the hosepipes must be periodically checked.

**6. Sewing machines:**

Sewing machines are very important machines and are largely used in leather goods manufacturing. No product could be made without sewing machines because the assembled components are permanently joined together by stitching. Quality of stitch is an important factor and it adds aesthetic value to the end product. Wide ranges of sewing machines with different attachments are used for the manufacture of leather goods.. There are different kinds of sewing machines, which are used for various purposes according to the needs of the industries. They are i) industrial flat-bed sewing machine, cylinder-bed sewing machine, post-bed sewing machine and zig-zag sewing machine. The main classes of sewing machines are flat bed and cylinder bed sewing machines, which are used by all leather product industries.

**i) Flat-bed sewing machine (Single needle lock stitch industrial sewing machine):**

Imported and indigenous flat-bed sewing machines are extensively used in small, medium and big leather goods industries. Flat-bed sewing machine is used for flat stitches i.e. stitching belts, wallets, passport covers, shoulder straps, softy leather goods etc.

**ii) Cylinder-bed sewing machine (Single needle lock stitch industrial sewing machine):**

Imported cylinder-bed sewing machine is used mostly in medium and big leather goods industries. It is used for stitching items with gussets i.e. wrist pouches, ladies handbags, shoulder bags, document cases, travel bags, etc. The small diameter of the lower swing arm together with an exceptionally large clearance between the upper and lower arms allow small leather articles to be moved about freely under the needle. The combined bottom, needle and upper feed mechanism ensure uniform stitches and give a neat and tidy seam. Various types of piping viz., flat piping, cloth or leather piping, plastic piping, piping reinforced with the coiled spring, cane or cord insert and edge binding could be achieved on the products by using appropriate piping attachments in the machine. In the flat-bed sewing machine, the clearance between the arm and the table is small and so they are suitable for stitching small articles with flat stitches and softy types of articles. But in the case of cylinder –bed sewing machine, the clearance between the arm and the table is big and so all types of articles with gussets can be stitched. Even flat stitches can also be done in the cylinder-bed sewing machine by fixing suitable attachment. Since both flat-bed and cylinder-bed sewing machines have the same parts except for the difference in the arms, the parts and functions of the cylinder-bed sewing machine are given in the table bellow

**(Fig.5-8):**

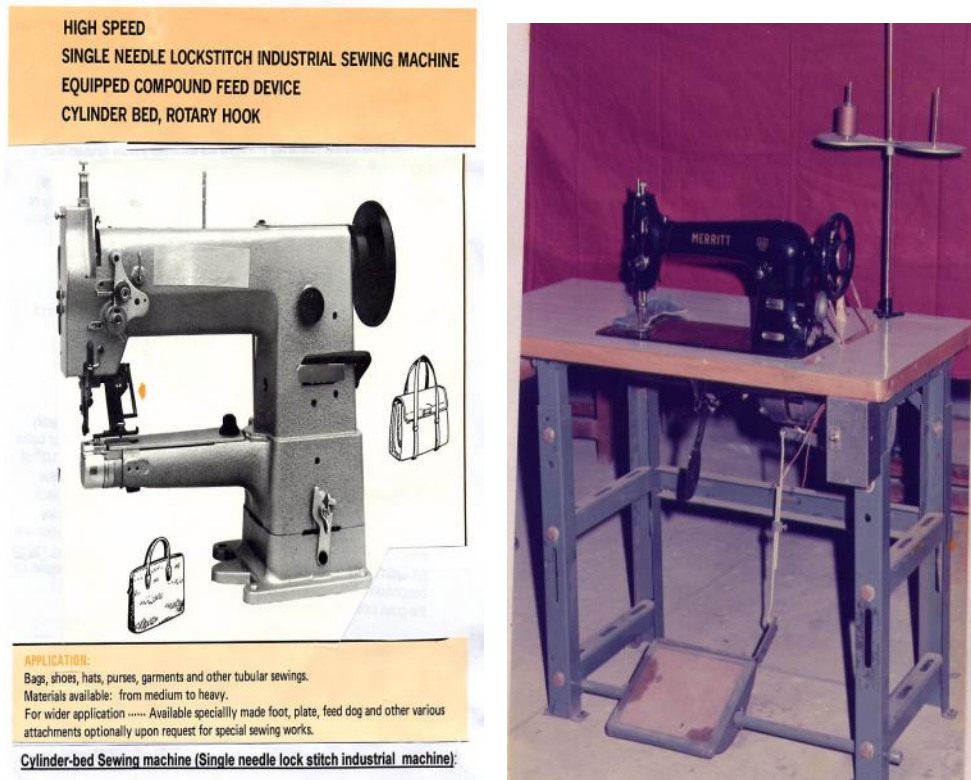

**Fig.5-8: Cylinder-bed sewing machine**

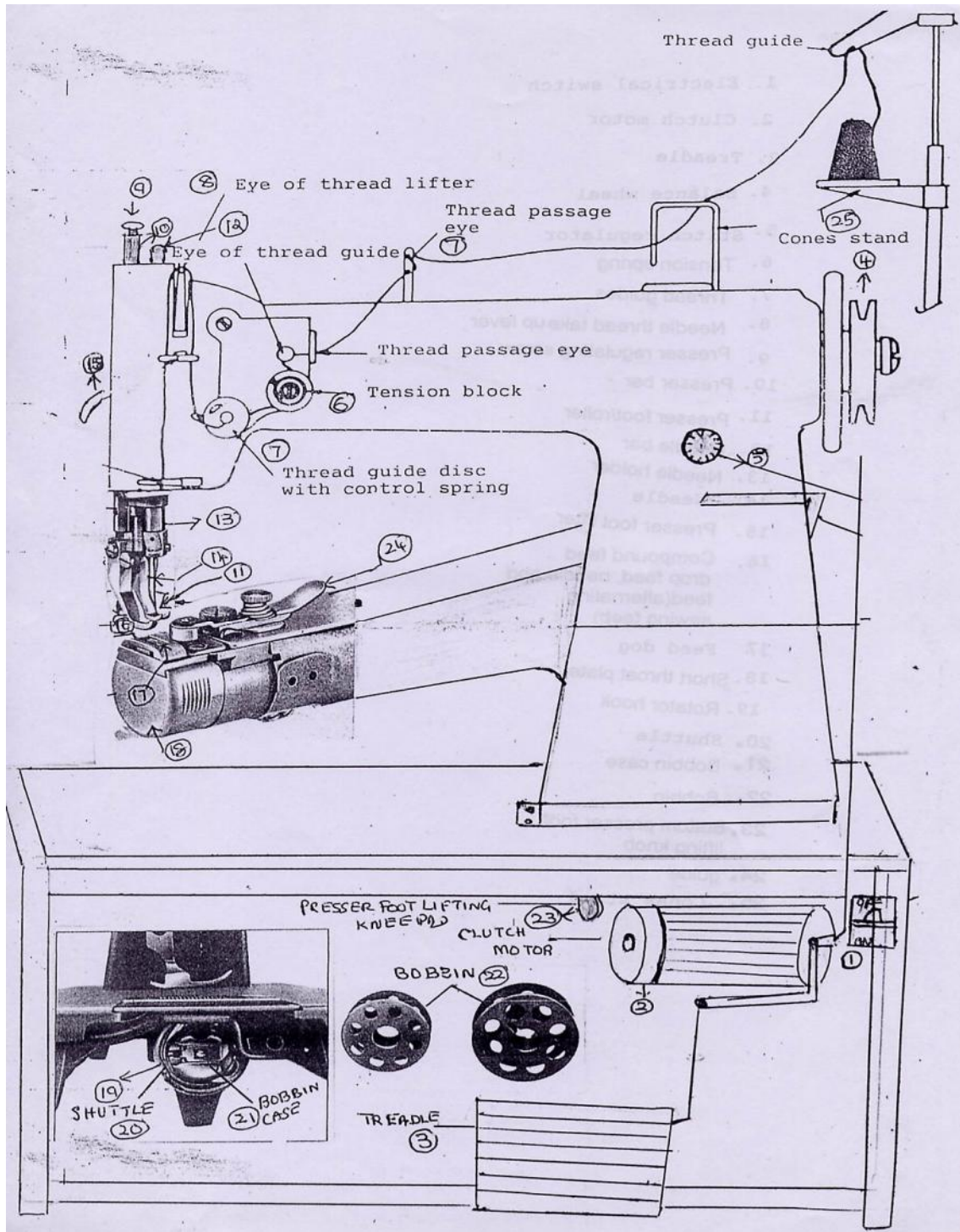

Fig.5-8 Flat and Cylinder-bed sewing machines

**Parts and functions (Table-6):**

Parts	Functions
Main switch	To supply electrical power to the machine
Clutch type treadle	To run or stops the machine
Balance wheel	To control the movement of the needle
Reverse feed lever	To make lock stitches at the beginning and at the end
Stitch length regulator	To select stitch length either in inch or metric system (stitches/inch or stitches/mm.)
Tension control regulator	To control the rate at which the thread feeds to the needle by a numbered dial
Thread guides	To guide the thread from the spool to the needle
Thread take take-up lever	To control the running of the thread during stitching
Presser regulating screw	To provide suitable pressure for easy feeding of the materials
Presser bar	To hold the presser foot
Needle bar	To hold the needle holder
Needle holder	To hold the needle
Needle	To stitch the components and products
Presser foot	To hold the material for stitching
Presser foot lifter handle / knee	To move the presser foot up or down during stitching
Combined bottom needle and upper feed mechanism (alternating feet)	To ensure easy stitching (without any skidding and puckering) and uniform, neat and tidy seam
Rotator hook	To change bobbin quickly and easily because of horizontal access rotator hook
Needle guard	To prevent the needle from breaking while stitching
Short throat plate with round edges and sharp single line feed dog	To sew a wide range of leather goods
Shuttle	To catch the top thread for stitching
Feed dog	To move the material for each successive stitch
Bobbin case	To control the bottom thread tension
Bobbin	To wind the bottom thread
Presser foot roller guide	To facilitate easy turning and stitching close to the edge of the components
Flat guide	To make perfect straight stitching
Thread stand	To hold thread spool for stitching

**Table-6: Sewing machine – Parts and its functions**



### **Operations:**

After making necessary adjustments, the matching thread of the product is inserted into the needle through the thread guides. The bobbin is also wound with the same colour thread. The machine is switched on and stitch is tested on a piece of material for perfect stitching and stitch length. If necessary, adjustments are made for perfect stitching. Then, the components of the products are stitched and sent for assembling. After assembling, the assembled components are finally stitched into products. The quality of stitching is carefully inspected while stitching the components as well as stitching the assembled components into products before sending the stitched products for final finishing process.

### **Caution**

- i. The machine must be cleaned and oiled periodically for smooth sewing performance.
- ii. The important parts, viz., shuttle, feed dog, throat plate, tension unit etc. must be periodically cleaned.
- iii. Thread of same thickness must be used in the needle and bobbin.
- iv. Appropriate needle must be used according to the thickness of the material.
- v. While changing the needle, the needle must be fixed in the correct position. Otherwise, not only the stitching performance gets affected but also needle may break.
- vi. While stitching, the material should not be pulled because; it will not only affect the stitch performance but also cause damage to the needle.
- vii. Only after pressing the needle into the component, the component must be turned for stitching. Otherwise, uniformity of stitch at the corners will be affected.

**Sewing machine problems (Table-7):**

<b>Problem</b>	<b>Possible cause and action</b>
Motor runs but machine does not operate	Tighten clutch at the hand wheel if clutch slipping or release bobbin wind control or adjust drive belt or replace if worn or broken or lubricate the machine if needs oil
Needle thread breaks	Incorrect threading or reposition the needle if needle is inserted incorrectly or decrease the needle tension if thread tension is too high or use correct size of needle if needle is of wrong size or make sure that the needle is not bent or burred at the tip or smoothen the path of the needle thread by emery paper or clean the feed dog clogged by lint or thread
Bobbin thread breaks	Smoothen the needle plate hole or replace needle plate if the needle plate edges are burred or wind bobbin thread correctly if bobbin is wound poorly or clean the area around the bobbin if bobbin case is entangled by lint or thread or decrease the bobbin thread tension if thread tension is too high or smoothen the edges of the bobbin case with emery paper or replace bobbin tension spring if burrs on rough edges on bobbin case or bobbin tension spring
Bobbin winds incorrectly or does not wind	Adjust incorrectly positioned bobbin thread or replace worn friction wheel or rubber rim
Needle breaks	Use needle of proper size if wrong size needle is inserted or replace the needle if bent or reposition the needle if the needle is inserted incorrectly or use the correct presser foot and needle plate if the presser foot or needle plate loose or of wrong type or insert bobbin case correctly if bobbin case inserted incorrectly
Thread loops or bunches	Adjust incorrectly set thread tension or clean lint from needle thread tension discs and bobbin area or replace the needle if bent or burred or rewind bobbin if not wound correctly
Machine does not stitch or it skips stitches	Use proper size needle or replace if bent or reposition the incorrectly inserted needle
Machine feeds fabric poorly or not in a straight line	Use the correct presser foot for the job or adjust the presser foot or remove the lint or thread clogged in the feed dog or replace the feed dog if its teeth worn out

**Table-7: Sewing machine problems**

### 7. Edge staining machine:

Edge staining machine is used for staining the raw edges of the cut-edged construction (Fig.5-9).



Fig.5-9 Edge staining machine

### Parts and functions (Table-8):

Parts	Functions
Switch	To supply electrical power to the machine
Reservoir	To store dye for staining
Electrical transformer	To regulate the voltage
Vibrator switches	To control the flow of dye
Beak	To enable to run the leather easily in the cavity
Turning stopper	To regulate the height of the cavity
Pedal	To regulate the uniform flow of dye

Table-8: Edge staining machine – Parts and its functions

### Operations:

The colour dye is filled into the reservoir. The electric transformer is regulated on the required voltage. The switch is turned on to the position 1 indicated in the vibrator. The raw edge is passed between the valve and the beak. The leather must run easily in the cavity. Turning the stopper placed under the small shaft with spring attached can regulate the height of the cavity. The pedal is pressed and at the same time the stopper is unscrewed in order to get the regulation of the dye. If the dye does not flow continuously, the switch is turned to the next position and so on until there is a uniform flow. After staining is done, the nozzle and the supporting foot are cleaned carefully with

the solvent. The stained edges are checked for quality. Different types of edge staining machines are used in industries.

**8. Straight edge folding and creasing machine:**

Edge folding and creasing machine is used to fold and crease simultaneously for making turnover edge articles with crease. This machine is used mainly for making small exportable leather goods viz. wallets, bill folds, credit card cases, key cases, passport covers, etc. (Fig.5-10).

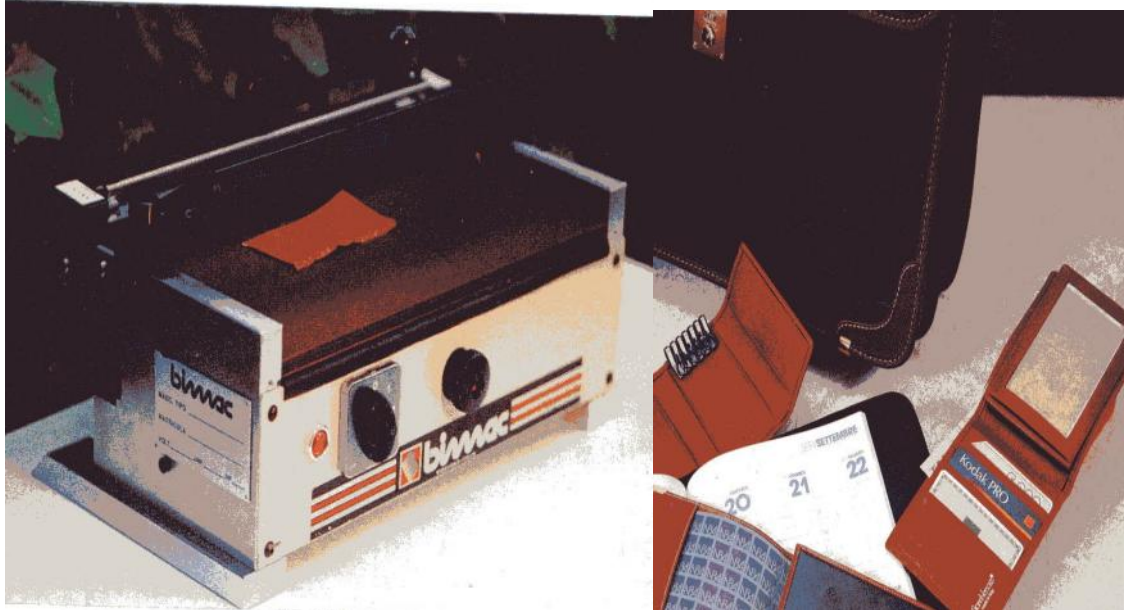

**Fig.5-10 Straightedge folding and creasing machine**

**Parts and functions (Table-9):**

Parts	Functions:
Switch	To supply electrical power to the machine
Creaser	To crease the leather components
Folding device	To fold straight the glued components
Fold width adjusting knobs	To adjust for the width of the folding
Thickness adjusting knobs	To adjust for the thickness of the leather components
Clutch type handle	To press the component for creasing
Thermostat control	To control the temperature for perfect creasing

**Table 9: Straightedge folding and creasing machine – Parts and its functions**

**Operations:**

The components, which require straightedge folding and creasing are first skived at the edges. They are then glued and fed into the machine. The required heat for perfect folding and creasing is adjusted using thermostat control. The handle is pressed till uniform folding and creasing is achieved. The width of the folding can be adjusted by

folding width-adjusting knobs. The maximum folding width is 2 cm and the maximum folding length is 30 cm. Different types of edge folding cum creasing machines and thermosetting and folding machines are used in big leather goods industries.

**9. Frame opening and closing machine:**

Framing machine is used for the manufacture of framed ladies purses and bags (Fig.5-11).



**Fig.5-11: Frame opening and closing machine**

**Parts and functions (Table-10):**

<b>Parts</b>	<b>Functions:</b>
Pneumatic system (air cylinder and turbo control)	To provide pneumatic pressure
Frame opening plate	To open the frame
Single stage foot control treadle	To provide pneumatic pressure for opening
Frame closing guide	To close the frame
Double stage foot control treadles	To provide pneumatic pressure for opening and closing

**Table-10: Frame opening and closing machine**

Before the frame is fixed to the bag, the slot of the frame is to be opened sufficiently so that the framing of the bag can be done without difficulty. The slot of the frame is gently pressed into the plate of the frame opening machine and the treadle is pressed. By means of air pressure, the top device comes down and opens the slot of the frame to a required gap. The frame is then removed for fitting to the handbag. The top of the assembled handbag is pushed into the slot of the opened frame perfectly and then placed under the closing device of the frame closing machine. The first treadle in the double stage foot

control is pressed. The frame is held firmly by the frame closing plate. Any adjustments to be made in straight alignment can be done at this stage. When everything is correct, the second treadle in the double stage foot control is pressed. Now the closing guide firmly presses the frame thereby perfect framing is obtained.

**Advantages over manual framing of the articles:**

- i. Fixing frames by hand may not be uniform.
- ii. Most of the times, the frames get dented by fixing manually with hand tools thereby the elegance of the product is lost.
- iii. Fixing the frames by hand takes enormous time.

**INDEGENIOUS MANUAL MACHINES:**

**1. Hand shearing machine:**

Hand shearing machine is used to cut reinforcement materials such as paperboards, straw boards, etc., in the manufacture of leather goods. It is very useful for cutting drawing sheets and paperboards in the pattern cutting process. It can also be used to cut leathers for making straps. Hand shearing machine is fitted with a graduated table, sliding right-angled plate with locking knob, guide, driving wheel with locking knob, shearing knife and treadle. A scrap tray is fitted under the table to collect the scraps (**Fig.5-12**)

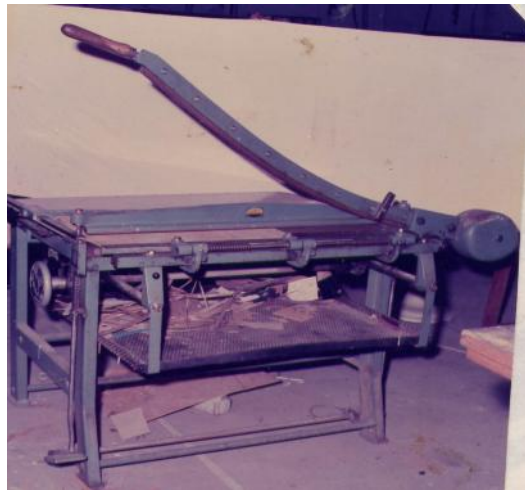

**Fig.5-12: Hand shearing machine**

**Operations:**

Before shearing materials, necessary adjustments are made in the machine, using graduated scale, sliding right-angled plate and guide. The materials are then placed one by one and sheared to required widths by pressing the hand shearing knife and treadle... In case of drawing sheets or thin paperboards, more than one can be placed depending upon the sharpness of the shearing knife and sheared. After shearing, the sheared components are inspected for quality of shearing.



**Advantages over hand cutting:**

- i. Speed of operation.
- ii. Accuracy and uniformity.
- iii. Least wastage.

**Caution:**

- i. Periodical sharpening of knife must be done otherwise ragged cutting will result.
- ii. The material must be held firmly by the treadle before shearing otherwise inaccuracy of shearing will result.
- iii. The right-angled plate must be used for straight cuttings at 90 degree angles.

**2. Gold embossing machine;**

Gold embossing machine is used to emboss logos, letters, floral designs, etc. in the leather components before assembling. The embossing machine is fitted with a pulley, a rubber covered roller, block holder with heating device, temperature control, base plate and handle. By pressing the handle, the movement of rollers takes place (Fig.5-13).

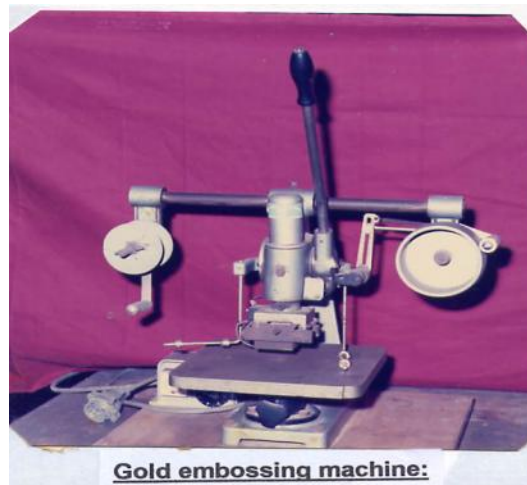

**Fig.5-13: Gold embossing machine**

**Operations:**

Design block or letter block is fitted to the base plate in the machine. The gold foil is inserted to the pulley, which passes under the block and then over the rubber roller. Suitable heat is provided to the block by means of temperature control device. Testing is done before embossing the components for the uniformity of embossing. The components are then placed one after the other and the handle is pressed. The gold foil

moves at every operation over the heated block. A sharp and uniform figure is embossed on the components.

### 3. Riveting machine:

Riveting machine is used to fasten the components during assembling process. Riveting machine is fitted with a riveting device, moveable spring stem and handle or treadle. Different sizes of dies can be fixed depending upon the needs (Fig.5-14).

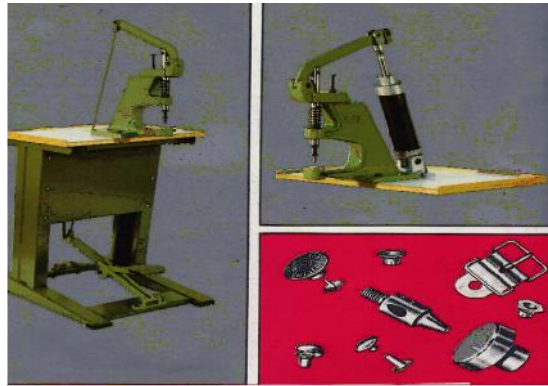

**Fig.5-14: Riveting machine**

#### Operations:

The components, which have to be joined, are first punched with holes. Then, suitable die is fixed in the machine. The rivet is introduced into the holes of the components and fed into the riveting machine and pressed. The riveting is done. While riveting, the pressure should be moderate. Excess pressure will damage the rivets. Pneumatic riveting machine with pedal is also used in bulk manufacturing.

### 4. Universal punching machine:

Punching machine is used to punch holes on straps, belts, watchstraps etc. Punching machine is fitted with a punching device, moveable spring stem and handle or treadle. Suitable punching dies can be fixed in the machine and punched for different sizes of holes (Fig.5-15).



**Fig.5-15: Universal punching machine**

**Operations:**

The strap is first marked with the pattern for punching holes. Suitable punching die is fitted in the machine. The strap is kept at the bottom plate and the handle or treadle is pressed for punching holes.

**5. Eyeleting machine:**

Eyeleting machine is used to fix eyelets in key cases, belts and stretch bags. Eyeleting machine is fitted with a cup at the top, eyelets sliding channel, eyeleting device and handle or treadle (Fig.516).

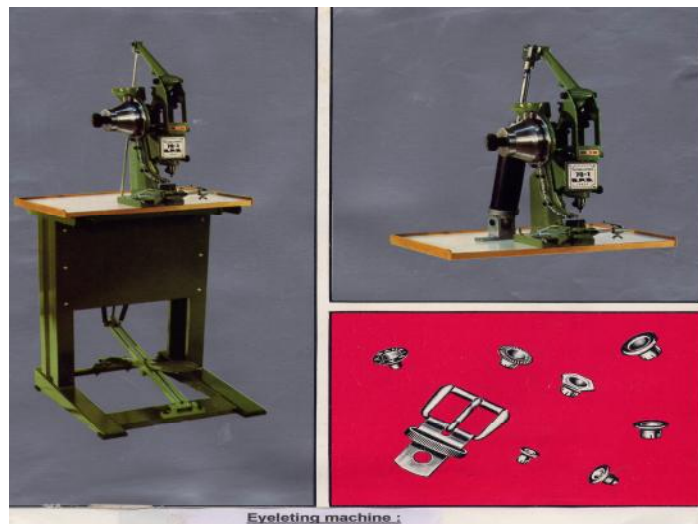

**Fig.5-16: Eyeleting machine**

## Operations:

The eyelets are put into the cup, which slide one by one for each operation. The products, which are to be eyeleted, are first punched with holes. Suitable eyeleting die is fixed in the eyeleting device. The hole of the product is pressed on the eyeleting device and the handle or treadle is pressed. Eyeleting is done. The process is continued till all the eyelets are fixed to the products. A variety of eyeleting device is available for various eyeleting works. Automatic eyeleting with pneumatic device is used in big industries.

## 6. Button fitting machine:

Button fitting machine is used to fix purse buttons in a variety of leather goods. Button fitting machine is fitted with a bottom fitting device, moveable spring stem and handle or treadle. Different sizes of male and female dies can be fitted to the machine for fixing different sizes of buttons. For each operation, a set of male and female dies is fitted in the machine (Fig.5-17).

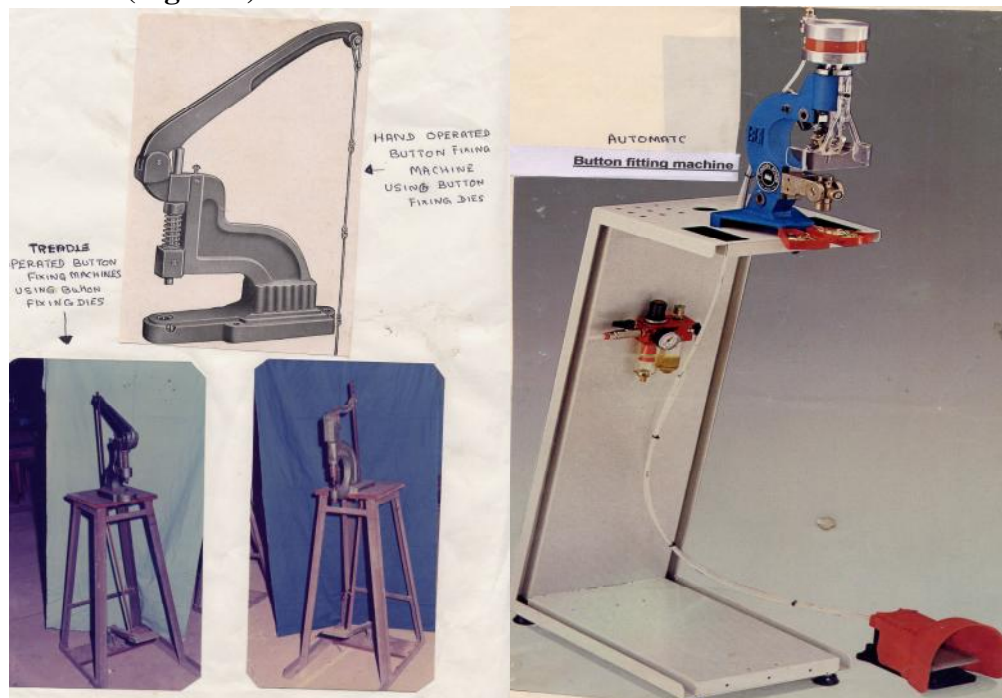

Fig.5-17: Button fitting machine

## Operations:

A set of purse buttons consists of cap, spring, rivet and stud. The leather components are first punched with suitable holes. The machine is then fitted with a set of male and female dies for fixing cap and spring. The cap of the button is pushed through the hole and placed over the bottom male die. The cap spring of the button is fitted to the spring stem. The handle or treadle is pressed gently. The cap and the spring get fixed in the first component. The dies are removed and another set of male and female dies are fitted to the machine. The rivet of the button is pushed through the hole and placed over the bottom male die. The stud of the button is fitted to the spring stem. The handle or treadle

is pressed gently. The rivet and stud get fixed in the second component. Both the components are pressed and the button gets fixed with a click sound. If no click is heard, the button is improperly fixed. So care must be taken to fix the buttons accurately. The process of fixing buttons is carried out as described above. After fixing buttons, the quality of the buttoning is checked.

### **7. Table polishing machine:**

Table polishing machine is used for smoothing or rounding edges and for polishing of raw edged leather articles. This machine is equipped with a built in motor, switch and a table. A switch serves for regulating the motor to run at two speeds for polishing and smoothing. On the right hand side of the shaft, is arranged a special grinding stone for rounding or smoothing edges. A horsehair brush, fitted by the side of the grinding stone, is used for doing additional polishing work on edges. On the other side of the shaft, are mounted a small and a large wooden polishing wheel which are suitable for doing good polishing works. A leather disk serves for applying polishing wax (**Fig.5-18**).

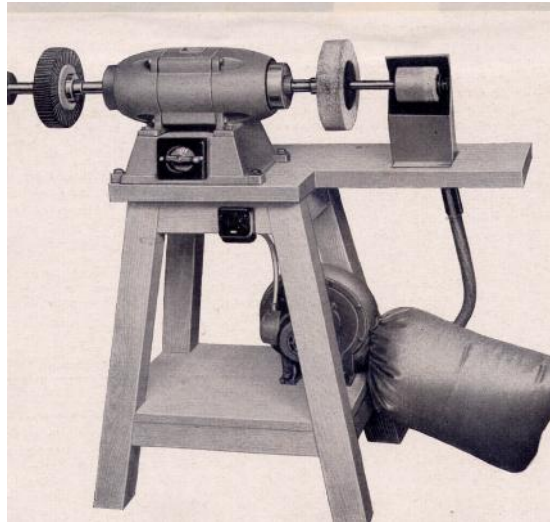

**Fig.5-18: Table polishing machine**

### **Operations:**

At first, the edges of the work piece are held pressed against the grinding stone. Then, matching dye is applied by hand and polishing is done by the wooden polishing wheels. Wax is applied by leather disk and polishing is done by the horsehair brush.





# Chapter 6

## Technology of Leather Goods Manufacture

The term “leather goods” is applied and confined generally to the articles made mainly of leather and intended for carrying personal belongings. Some articles are carried in pockets and some are carried in hand or shoulder. The variety of leather goods we come across every day is countless. When there are a variety of articles that differ in size, shape, design and methods of construction, it is absolutely necessary to know the various techniques involved in the manufacture of leather goods:

### **Introduction to designing**

In the process of manufacturing and marketing, designing is considered to be the most important process. In the principle of designing, a good design should be easy for making and selling. The design should be simple and attractive because production and productivity are the key factors for a successful commercial venture. Assembling too many components for multi-purpose functions may be avoided as it affects the important aspects of designing viz., size, shape, structure and aesthetic value. In good designing, techniques and technical skills are very important. A good design should not impair the functions of the products for which they are manufactured. For example a wallet or a coin purse must hold currencies or coins and serve for its functions. If the products do not serve for its intended functions, any added decorations to enhance the rich appearance of the articles will be of no use and such designs will affect the sale of products in the markets to a considerable extent. Some designs may be very easy to manufacture due to less assembling components but leather consumption may be more resulting in more wastage of leathers but it is compensated with ease of operation and increase in productivity. Some designs may be very difficult to manufacture due to multiple components assembly but leather consumption may be less resulting in less wastage of leathers but the production takes longer time and productivity slows down. So, in good designing, a judicious blend of production techniques and productivity, cost saving, added value and quality control aspects must be taken into consideration. In the process of designing, a good designer plays an important role. He must foresee the fashion trend and frequent changes of designs and styles. He must be well versed with CAD/CAM techniques to create newer designs of international standards to suit to the global markets. He must also be aware of colours, colour combinations, raw materials, etc. In fact, the designer stands between the market and the manufacturer. The designer designs a few articles reflecting the seasonal fashion trends for displaying in international fairs to attract the potential buyers. The designer also designs products as per the specifications given by the regular customers and sends the drawings with details to sample making section for making products. After making the products, they are sent to the buyers for approval. Once the buyers approve the products, they are sent to pattern making section for cutting patterns for the manufacture of the products.



**Fig.6-1 designing for leather products**

### **Introduction to pattern making**

In the manufacture of leather goods, pattern making and pattern cutting are the most important and fundamental in fabricating leather goods. It forms the very core and the beginning. Before making any leather goods, the sizes and geometrical shapes of its parts are first cut in paper. Such patterns, which are cut in paper, are called paper patterns. The paper patterns are stuck on thick millboard or a white board, using adhesive and then cut into cardboard patterns. By using the cardboard patterns, leathers, linings, foam and reinforcements needed for making leather goods are cut. The economy of leather goods depends upon pattern cutting, which determines the cost of production. Since patterns are cutting guide, it must be very accurate. It helps to ensure that the materials are cut accurately without any wastage. The art of pattern cutting requires anticipation, sound judgment, and cultivated style of approach with a sense of quality control. In leather goods making, two kinds of patterns are used. They are making patterns and cutting patterns.

### **Making patterns**

The patterns, for the parts of the product, are cut to the correct measurements and shapes. These patterns are called making patterns and are largely used for making **cut-edged articles**.

### **Cutting patterns**

The patterns, for the parts of the product, are cut with allowances for folding and stitching. These patterns are called cutting patterns and are largely used for making **fold-edged or turn over- edged articles**.

Both the making patterns and cutting patterns are used for making **stitch and turn-edged articles**. To make less number of products, cardboard patterns are used for cutting components. To make more number of products, aluminium or galvanized metal patterns are used for cutting components. To manufacture in bulk, the cardboard patterns of the product are converted into clicking dies and the components are cut in the hydraulic clicking press.

**Diagrammatic illustration of pattern cutting process - Size 10 cm x 8 cm:**

- i) Fold an irregular paper of size 11 cm. X 9 cm. in the centre Punch with an awl at the top corner. Open the paper and place the scale at the punched marks. Hold the scale firmly and cut with a knife. The top edge of the paper gets straightened (**Fig.6-2**).
- ii) Fold the straightened paper again and place the scale at the top straightened edge and punch a mark with the awl to the length of 10 cm at the bottom. Open the folded paper and place the scale at the punched marks. Holding the scale firmly cut the paper with the knife. The paper pattern of 11 cm x 10 cm is got.
- iii) Fold the paper again and place the scale at the top folded end and punch a mark with the awl to the width of 4 cm. Place the scale again at the bottom folded end and mark with the awl to the width of 4 cm. Holding the scale at the punched marks, cut the paper with the knife. The paper pattern of 10 cm x 8 cm is got.

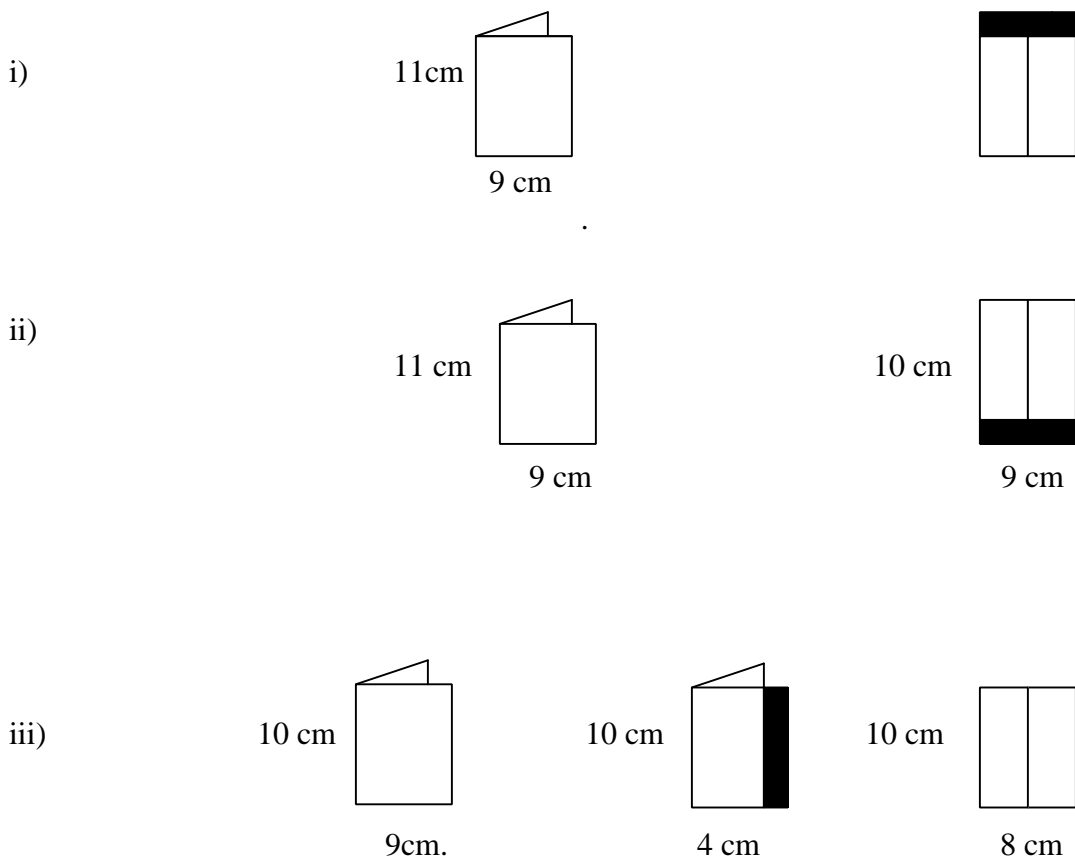

**Fig.6-2: Pattern cutting process**

In the process of pattern making, pattern maker is considered to be a very important person next to the designer. A good pattern maker must be aware of different types of finished leathers and their suitability in making different types of leather goods. He must be well versed with the techniques of fabrication and types of constructions. He must have the essential knowledge in elementary mathematics, measurements and use of geometrical instruments for drawing geometrical shapes viz. square, rectangle, circle, etc. and other odd shapes. He must be aware of different types of fittings, linings, reinforcements and other miscellaneous items, which are used in leather goods making. The pattern maker must give in each pattern the following details, which would help the cutter in the subsequent process of cutting to cut components easily and swiftly.

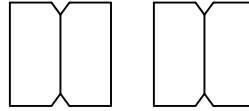
- i. Name of the product and reference number.
- ii. Name of the parts (front, back, gusset, pocket, flap, handle, etc.)
- iii. Details of the raw materials (leather, lining, foam, reinforcement, etc.)
- iv. Number of components to be cut.
- v. Centre points for perfect joining of the components. → 
- vi. Marks or slots for fixing fittings and zips.
- vii. Stitching width and stitches per inch or length of stitch in mm.
- viii. Use of good and defective leather components for visible and invisible parts of the product

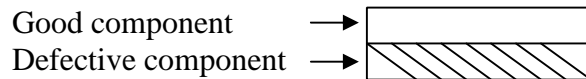

### SEQUENCE OF OPERATION IN LEATHER GOODS FABRICATION

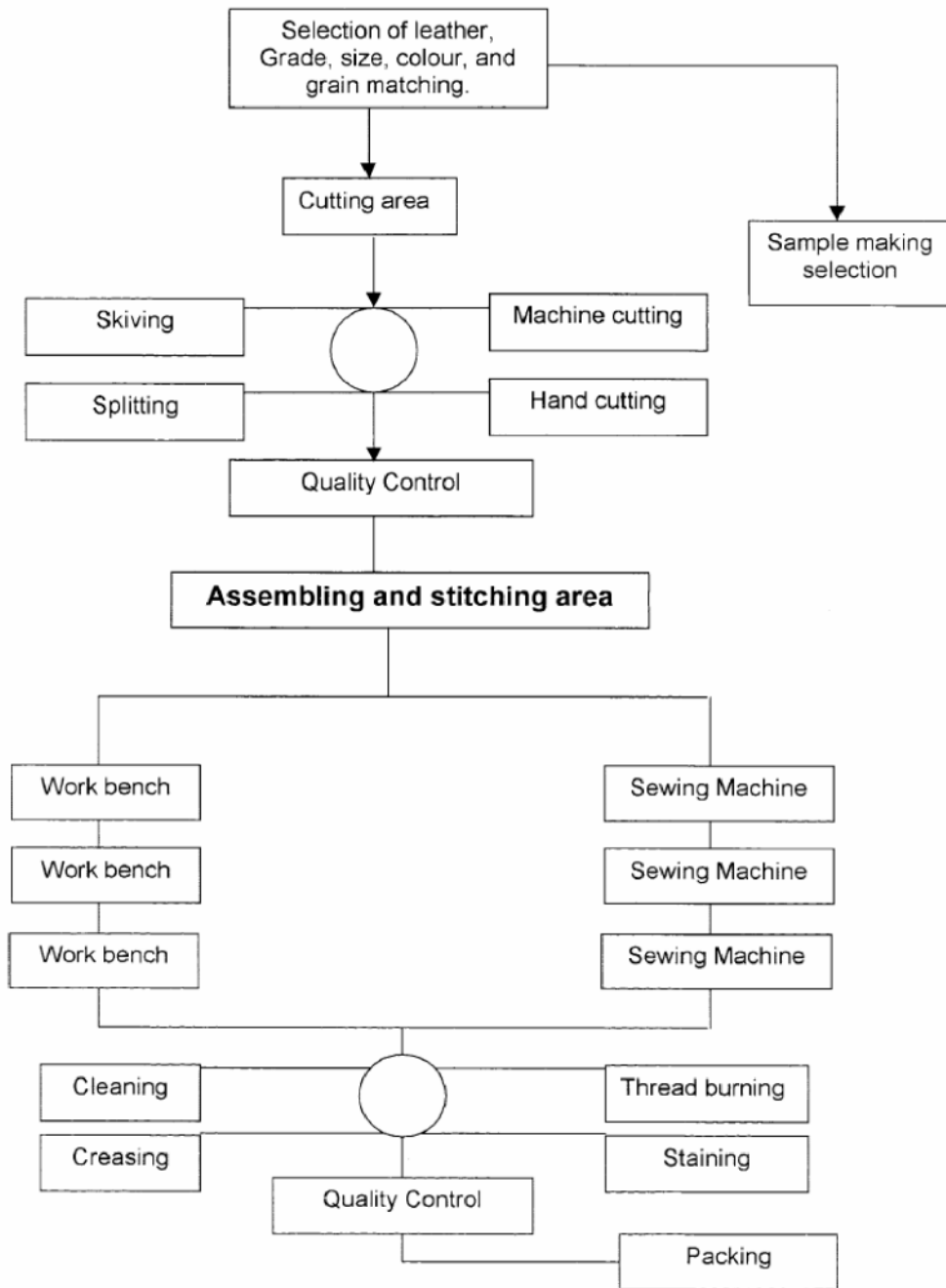

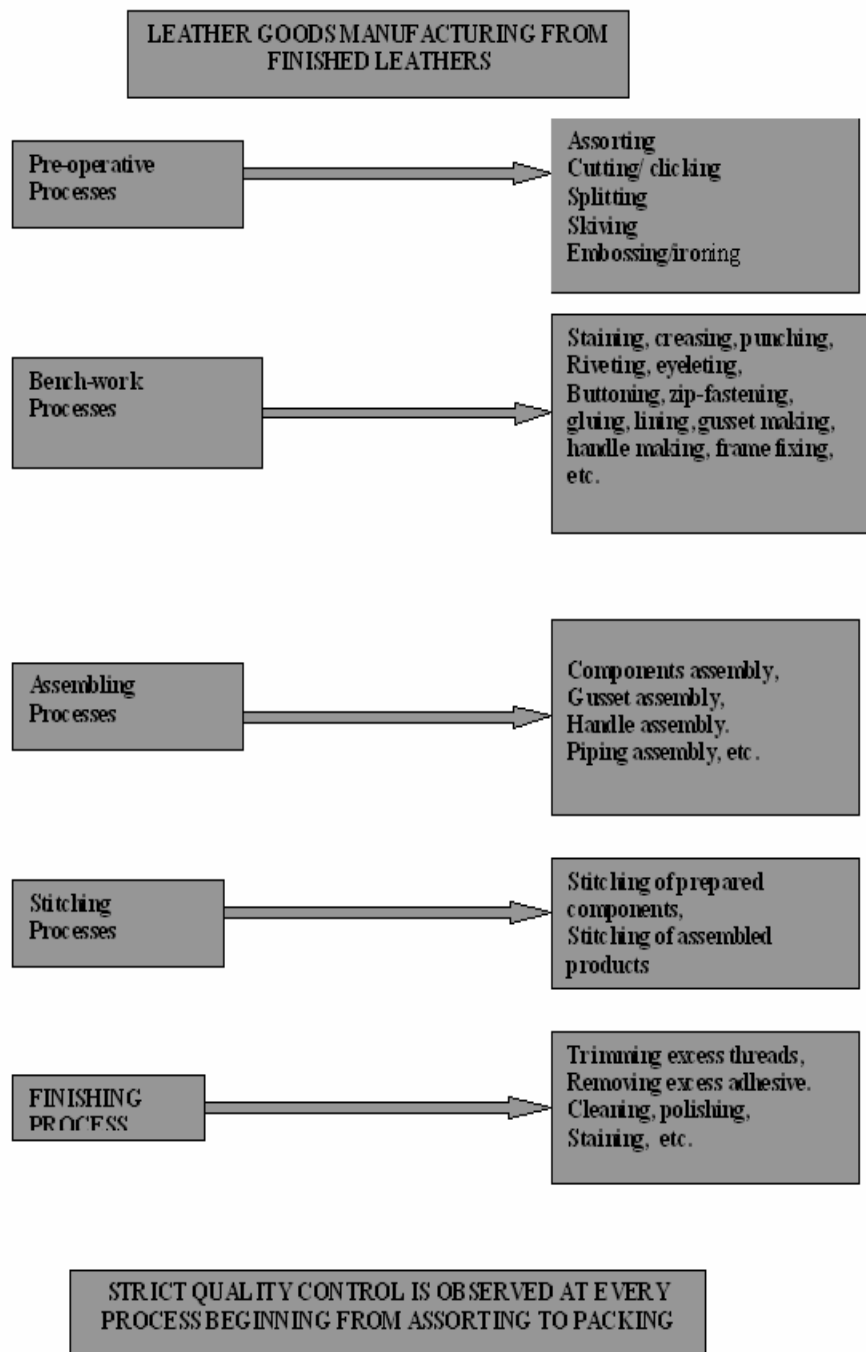

Fig.6-3: Flow diagram for leather goods manufacturing



## Leather Goods Manufacturing Processes:

### Pre-operative processes:

Pre-operative process consists of (a) assorting, (b) cutting/clicking, (c) splitting, (d) skiving, and (e) embossing.

#### (a) Assorting:

Assorting is a vital process carried out by highly skilled technicians before cutting. Assorting must be done under perfect lighting system so that quality of assorting can be assured. Leathers are assorted according to thickness needed for various parts of the product, size, colour, defects, texture, grain and stretch/elasticity. The assorting technicians must be aware of the defects caused by mechanical injuries and diseases to the hides and skins. The defects are distinctly marked by silver marking pencil (**Fig.6-4**)



**Fig.6-4 Assorting leathers**

The following tables illustrate the principal sources of physical damage and their causes and diseases and parasitic infections of hides and skins and their causes:

#### Mechanical injuries affecting hides and skins (Table 6-1):

Type	Cause
Brand marks	Effects of severe heat (hot iron)
Scratch marks	Thorn brushes, rough fencing and others
Horn rakes	Fighting
Yoke and harness scars	Improper designs or fitting
Goad marks	Excessive use of sharp or heavy sticks
Flay cuts	Improper techniques or excessive haste
Vein marks	Old age or poor feeding
Salt stains	Discoloration of the surface of hides and skins during the curing process
Damage of grain and texture	Lack of storing conditions and preserving agents

**Table 6-1: Mechanical injuries affecting hides and skins**

**Diseases and parasitic infections of hides and skins (Table 6-2):**

Name	Cause
Ringworm	Fungus
Pustular dermatitis	Bacteria
Lumpy skin disease	virus
Mange	Parasitic mite
Warble fly	Parasitic fly
Ticks	Boophilus micropilus and others
Lice	Sucking and biting species
Anthrax	Bacillus anthracis
Small pox	Virus

**Table 6-2: Diseases and parasitic infections of hides and skins**

After assorting, the leathers are checked for quality and sent for next unit operation of cutting.

**(b) Cutting/clicking:**

Cutting is the second unit operation after assorting. In the process of leather goods making, cutting is considered to be one of the most important operations. Cutting is the term used for – cutting leather components, linings, foam and reinforcement materials using patterns for making leather goods. Cutting is done either by hand cutting or by machine cutting in the hydraulic clicking press. Cutting straps is done in the strap cutting machine while reinforcement boards are cut in the hand shearing machine.

**Hand cutting:** Hand cutting is done usually in small leather goods industries using either cardboard patterns or metal templates. Hand cutting is done on an inclined wooden table fitted with a galvanized zinc sheet or teflon sheet on its top. A sharp hacksaw blade knife made of tempered high-speed steel is used for hand cutting. The cutting knife is used to cut the leathers and other materials like linings, foam, reinforcements, etc used in leather goods making.

**Machine cutting:** machine cutting is done in the case of bulk production. The leathers are placed one by one on the teflon board of the hydraulic clicking press and then components are cut with the dies. Press cutting ensures speed of operation, accuracy and uniformity and least wastage (**Fig.6-5**).

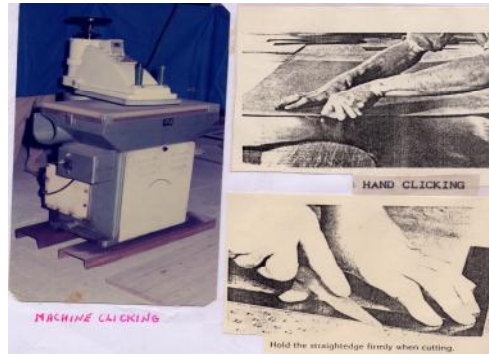

**Fig.6-5: Machine and manual cutting**

In the process of cutting, the cutter plays a vital role because the economy of production depends upon his skill in placing patterns, maximizing the cutting value and minimizing the wastages. He must be aware of structure, sections and quality variations of the skin. The cutter is, therefore, considered to be the most important person after designer and pattern maker

**Fig. 6-6).**

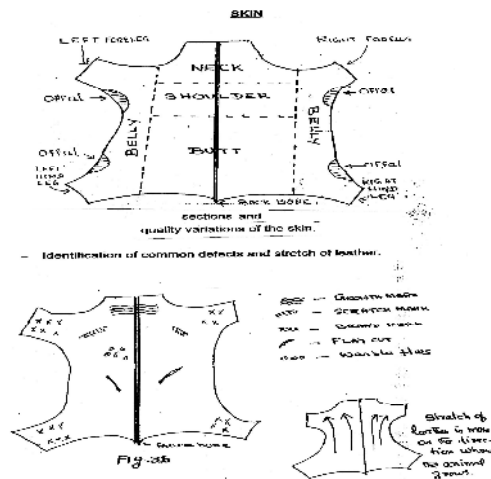

**Fig.6-6: Structure and section variations of skin**

**Butt:** Butt is firm and a best part of the skin. It has good grain texture, even substance and usually of good colour.

**Shoulder:** Shoulder is the second best portion. It may contain growth marks but it is firm and tight.

**Neck:** Neck is the third best portion. It may be thick but has loose grain. It is poor in strength. In the case of hides it may have large growth marks.

**Belly:** Belly is thin and has loose fibrous structure. It is poor in quality.

**Shank:** Shank may vary according to the type of the skin. It is usually the poor part. Since it is stretchy with wrinkles, it may or may not be used.

**Offal:** Offal is very pliable and stretchy and hence it is not normally used.

**Backbone:** The backbone area may be quite pronounced especially in the case of goat and hence it is avoided. A heavily pigmented finish may conceal it to make it usable.

**Key points to be remembered during cutting:**

- i) Make sure of correct patterns and markings.
- ii) Examine for defects size and shape of the skin.
- iii) Selective cutting must be practiced. The best part of the article demands the best part of the skin.
- iv) Visible part must have good grain surface and section covered could contain grain defects.
- v) Good cutting begins with a sharp knife. Less sharpened knife or blunt knife cuts the leather with ragged edges.
- vi) The angle between the edge of the knife and the cutting board depends of the hardness of the material being cut. A small angle for very soft materials like fabric and a greater angle for hard materials like leather and reinforcements.
- vii) Over-cutting and under-cutting must be avoided.
- viii) Patterns must be placed in such a way to ensure quality, economy and minimum wastage.
- ix) Straight-line cutting must be done first with steel scale. Curved line cuttings or irregular shapes must be cut with templates.
- x) Cutting must be done on a smooth surface of softwood or galvanized iron plate or zinc plate for cutting accuracy.
- xi) Place the pattern on the leather and initiate cutting from left to right.
- xii) Start cutting from left top corner of the pattern and end at the right bottom corner as shown in figure:

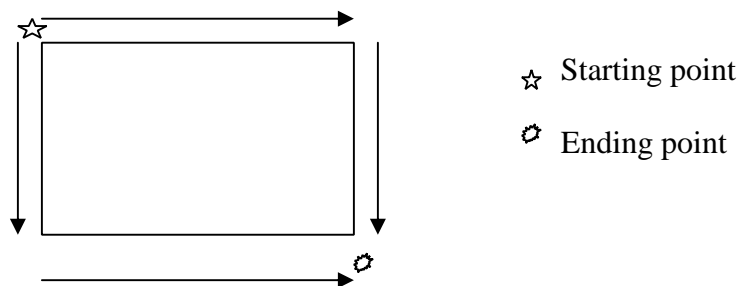

- xiii) Use the least number of cutting strokes.
- xiv) Cut through the leather in one stroke.
- xv) Intermittent cutting must be avoided as it may damage the components.
- xvi) Place the patterns suitably on the leathers to achieve maximum cutting with least wastage.

**Strap cutting:**

Strap cutting is the third unit operation after cutting. Strap cutting is done in the strap cutting machine. The machine enables to cut straps for belts, piping and handles for shoulder bags. The width of the strap ranges from minimum 3 mm. to 150 mm. The strap-cutting machine can also perform the function of an embossing press by changing the plain roller with the design roller. This can transfer design prints on the leather components. After strap cutting, the leather straps are checked for quality and then sent for splitting (**Fig. 6-7**).

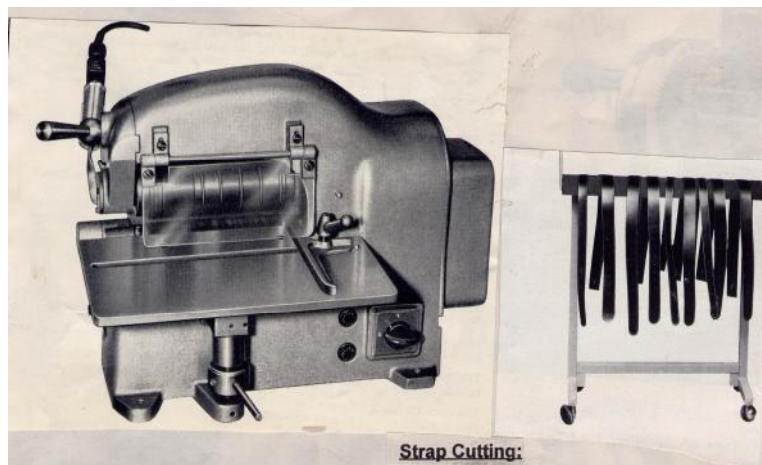

**Fig.6-7: Strap cutting**

**Board cutting:**

Reinforcement boards are cut in the hand shearing machine for use in making leather goods. After cutting process is over, only leather components are sent for splitting and skiving. The other components viz. lining, foam and reinforcements are kept safely in plastic trays.

**(c) Splitting:**

Splitting is the third unit operation after cutting/clicking. Splitting is done to get uniform thickness. Splitting enables reduction in thickness of the leather components to the required degree, which helps easy assembling of the components. Since leather goods are fabricated with varied thickness, it is necessary to split the leather components in the splitting machine according to the requirements. The top grain layer is used and the bottom split is let off. After splitting, the leather components are checked for quality and sent for next unit operation of skiving (**Fig.6-8**).



**Fig.6-8: Splitting of leather components**

**(d) Skiving:**

Skiving is the fourth unit operation after splitting. Skiving is the process of cutting the section of leather at the edges to reduce its thickness for folding. Without this essential operation, no articles could be fabricated. Skiving is done both by hand and machine.

**Hand Skiving:**

Hand skiving requires a great deal of skill. It is done on a smooth surface like granite or marble stone, as it does not absorb dyes or moisture. These stones enable smooth skiving. Skiving is done with a paring knife in which one side of the knife is beveled. High quality tempered power hacksaw blade is used for making skiving knife. The knife is held in such a way that it removes the required thickness at the edges for folding. The skiving should be stopped when suitable and uniform thickness is obtained at the edges for perfect folding. Care must be taken that the edges of the component are not thinned down more than the required thickness as it may weaken the components and also make the components unfit for fabrication.

**Machine Skiving:**

Since hand skiving is a laborious process and needs high skill for perfect and uniform skiving, machine skiving is preferred in modern times for bulk skiving in the manufacture of leather goods. The machine does the reduction of substance at the edges very accurately and at the same time, the productivity is increased. By using different types of presser foot, a variety of skiving can be obtained. There are four types of skiving, which are commonly used in fabricating leather goods. They are parallel skiving, channel skiving, bevel skiving or taper skiving and fine edge skiving or featheredge skiving.

**Parallel skiving:**

In parallel skiving, the substance is removed with uniform thickness to double width. Parallel skiving is used in turnover works.



### Channel skiving:

In channel skiving, required depth of skiving is done using channel skiving presser foot for easy folding. Channel skiving is used for making instrument cases, transistor cases, camera cases, tool kits, etc.

### Bevel skiving or taper skiving:

In bevel skiving, the presser foot and the feed roller are adjusted to a suitable angle to get bevel skiving. This type of skiving is used in the fabrication of Box work construction. Bevel skiving is also done in joining straps. In bevel skiving, the edge of the component is thinned down to zero thickness.

### Fine-edge skiving or feather-edge skiving:

In fine-edge skiving or feather-edge skiving, the guide is adjusted close to the edge of the component. Then, the presser foot adjusting screw is adjusted to a required depth of skiving. Fine-edge or feather-edge skiving is obtained. Fine-edge skiving is done in most of the articles (Fig.6-9).

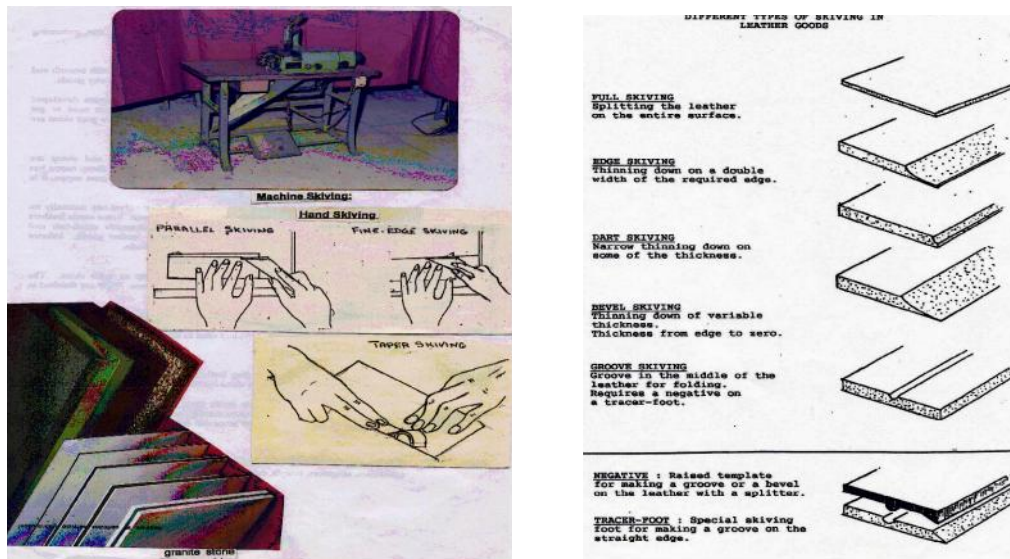

Fig.6-9: Machine and manual skiving/types of skiving

After, skiving, the components are checked for quality of skiving. The leather and lining components are sent for embossing.

### (e) Embossing:

Embossing is the fifth unit operation after skiving. Embossing is also called plating. Embossing is done in hydraulic embossing machine, which works on vacuum pressure. It has also heating device. Before assembling process, the components are plated or ironed with suitable heat and pressure to make them free from wrinkles due to constant handling for various operations. Sometimes, glued components are also pressed for

perfect lamination. By changing the plain plate with design plates, different designs can also be embossed on the components.

After embossing, the components are checked for quality. All the components viz. leather, lining, foam and reinforcements are sent for bench work operations (**Fig.6-10**).

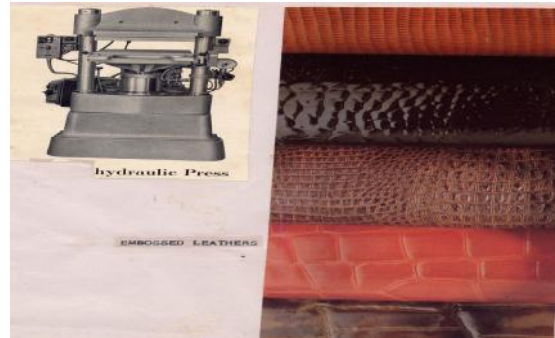

**Fig.6-10 Embossing of leathers with design prints**

### **Bench work Processes:**

Bench work processes are carried out by team of skilled technicians headed by highly skilled supervisors. In bench work processes, the components are prepared with linings, zips, folding, gussets, piping, handle, etc. for subsequent process of assembling.

Some components may need immediate stitching and some may not. The prepared components, which need immediate stitching, are sent for stitching. Bench operations comprise of (a) staining, (b) creasing, (c) punching, (d) riveting, (e) eyeleting, (f) buttoning, (g) zip fastening, (h) gluing, (i) lining, j) gussets making, (k) edge folding and (l) handle making.

### **(a) Staining:**

Staining is done on articles made by cut edge construction. The edges of the components are smoothed with emery paper first and then stained with water-soluble pigments using a wire brush with an absorbing cotton ball. The staining is done carefully without damaging the surface of the leather components. After drying the edges are wax polished and rubbed with a piece of smooth cloth vigorously for glossiness. In case of bulk production, edge staining machine is used to stain the edges (**Fig.6-11**).

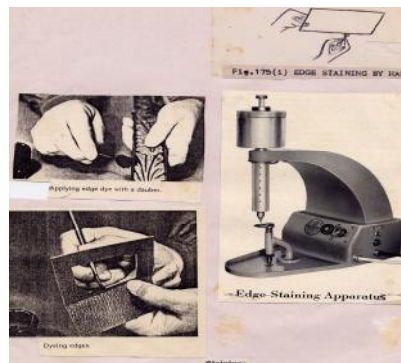

**Fig.6-11 Edge staining of leather components**

### (b) Creasing:

Creasing is done on the leather components with a suitable temperature. Creasing is done on cut edges as well as folded edges. Creasing helps in compressing the cut fibres at the edges and thus strengthens the edges. Creasing gives a permanent, slightly darker and glossy line. It improves the elegance of the products. It also gives a decorative and aesthetic appearance. Using a variety of creasers viz. single head creaser, double head creaser and adjustable creaser, creasing is done. Care is taken to see that the working edge of the creaser is kept smooth to avoid scratching during creasing operation. The tip of the creaser is slightly rounded off for smooth sliding while creasing (Fig.6-12).

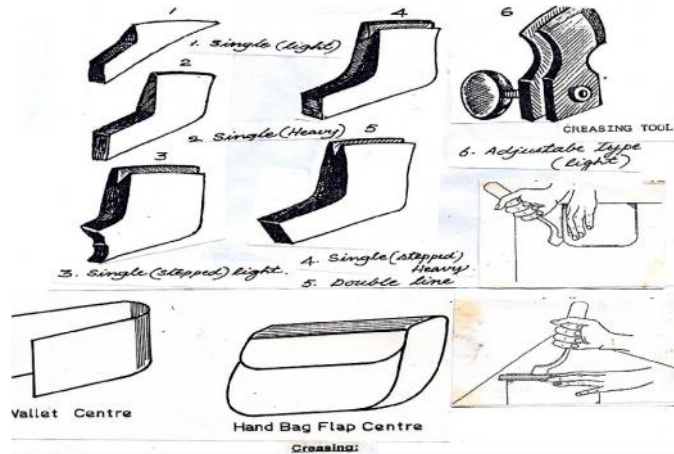

**Fig.6-12 Creasing of leather components**

**The following points must be remembered while creasing:**

- i) The creasing line must be close to the edge.
- ii) The line marked should be distinct and glossy appearance.
- iii) Suitable temperature must be needed for perfect creasing.
- iv) The straight lines must be creased first and then the corners.
- v) In case of bulk production, creasing machine is used for creasing.

### (c) Punching:

Punching is the process of making holes in leather components using a set of hole punching tools for varied sizes of holes needed for fixing fittings. Holes are made to fix buckles, buttons, eyelets, rivets, rivet buttons, studs etc. Punching holes are done in the articles like belts, watch straps, shoulder straps etc to insert the buckle prong. In case of bulk production, punching is done by hand or treadle operated punching machine (Fig.6-13)

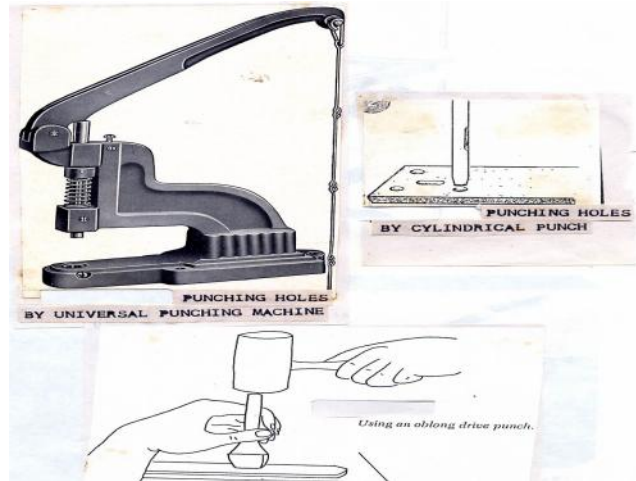

**Fig. 6-13 Punching of leather components**

**(d) Riveting:**

Riveting is done with rivets and rivet buttons using riveting tool for fixing handles, hinges, locks, etc. and also for joining assembled components. Riveting is also done in the riveting machine in case of bulk production. Automatic and Pneumatic riveting machines are used in big industries (**Fig.6-14**).

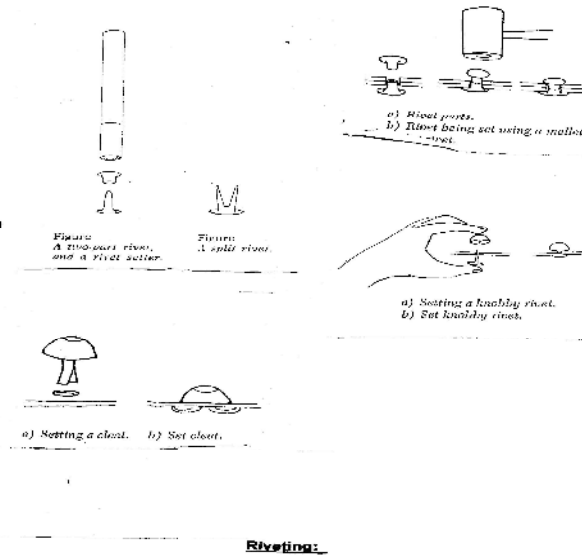

**Fig.6-14 Riveting of leather components**

**(e) Eyeletting:**

Eyeletting in articles is done by eyeletting tool. Coloured small eyelets are used to fasten key hooks fittings in key cases while fancy eyelets are used in stretch bags. In case of bulk production, an automatic eyeletting machine is used for eyeletting (**Fig.6-15**).

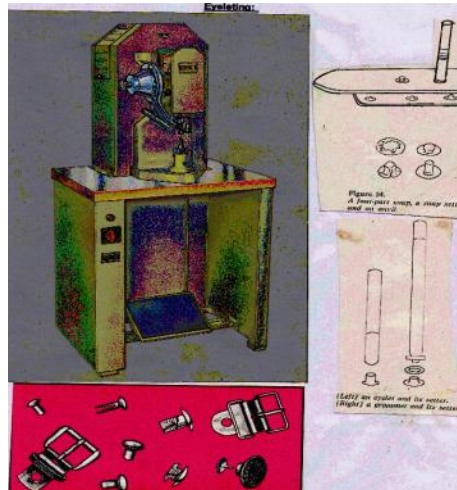

**Fig.6-15: Eyeletting of leather components**

**(f) Buttoning:**

Purse buttons of different sizes (3/2, 3/3, 4/3 and 7/7) are extensively used in leather goods. The button-fitting tool is used for buttoning. When fixing the buttons, care is taken to hammer the buttons gently as heavy hammering may damage the buttons. Since hand operation is a slow process, treadle operated or hand operated buttoning machine is used which ensures speedy operation and perfect setting of buttons. Automatic buttoning machine is used in big industries (**Fig.6-16**).

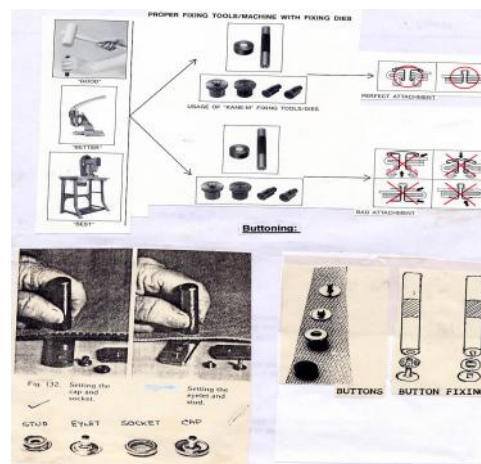

**Fig.6-16: Buttoning of leather components**

**(g) Zip fastening:**

Zip fasteners are extensively used in leather goods making because they enable quick opening and closing of the products. They are generally used in softy types of leather goods. Different types of zips in different colours are fixed according to the needs of the products and also to match the colour of the products. There are 3 types of zip fastening, which are commonly used in leather goods making. They are – (i) slot seam fastening (ii) lapped seam fastening and (iii) invisible seam fastening



**(i) Slot seam fastening:**

The slot of the zip pocket is cut in the component using pattern. The zip tape with the runner is cut according to the size of the slot and then attached in the slot using double face adhesive tape. The runner is moved and checked for smooth and perfect closing. The stitch is then made. The slot seam fastening is used as a closing device for pockets in leather goods. Slot seam fastening can also be done by folding the edges of the slot.

**(ii) Lapped seam fastening:**

The top gusset pieces are cut with the patterns. The zip tape with the runner is cut according to the size of the top gusset. The zip tape is opened by the runner and separated. Each part of the zip tape is attached to the gusset pieces with the double adhesive tape. The runner is inserted to join the top gusset pieces and checked for smooth closing. The stitching is then made. Lapped seam fastening is used as a closing device in most of the leather goods, in particular softy types of leather goods.

**iii) Invisible seam fastening:**

In this type of fastening, when the zipper is closed, all that shows on the article are a plain seam and zip tab only. The slot of the zip pocket is cut using pattern. The zip tape with the runner is cut according to the size of the slot. Two folded pieces are attached in the slot using adhesive in such a way that its edges exactly meet at the centre of the zip teeth. The zip tape is then attached in the slot using double face adhesive tape. The runner is moved and checked for easy and smooth closing. The stitching is then made. The other way of invisible zip fastening is – the slot of the zip pocket is cut using pattern, which has centre and v cuts. The zip is then attached using double face adhesive tape and the runner is moved and checked for smooth running and closing. The stitching is then made. By this technique, the teeth of the zip are fully covered leaving the runner out. Invisible zip fastening is used as pocket closing device. This type of fastening enhances the elegance of the products (Fig.6-17).



**Fig. 6-17: Different types of zip fastening**

## (h) Gluing:

Adhesion plays a vital role in assembling components viz. leather, lining and reinforcements during fabrication of the products. Further strength of the parts can be achieved by stitching. There are two types of adhesives, which are extensively used in the fabrication of leather goods. They are (I) temporary adhesive and (ii) permanent adhesive (Fig.6-18).



**Fig.6-18: Gluing of leather components**

### (i) Temporary adhesive:

Rubber adhesive is a temporary adhesive as it gives temporary bonding effect and so stitching is necessary after joining the components. It is buff coloured natural rubber adhesive. It is easy spreading characteristics coupled with cleanliness, flexible bondage and economy of application make it particularly suitable for general works. It gives a firm grip while stitching and helps in making articles with stitches.

#### **Application:**

Rubber adhesive is applied uniformly to the surface to be bonded. After achieving maximum tack development, the surfaces are joined. The joined surfaces are rolled down with a smooth roller to remove air bubbles. The components are then taken for stitching.

#### **Demerits of temporary adhesive:**

Rubber adhesive is composed of crepe white natural rubber and petrol (Gasoline). The components assembled with rubber adhesive separate after sometime when left unstitched. This is because the solvent petrol in the rubber adhesive evaporates and only the rubber is left. Rubber starts melting slowly due to atmospheric conditions. It is therefore necessary to stitch articles glued with rubber adhesive. It is inflammable and produces toxic vapours.



## **(ii) Permanent Adhesive:**

Synthetic rubber adhesive in solvent medium is a permanent adhesive as it gives permanent bonding effect. It is extensively used in leather articles which are made without stitches and also in attaching components where stitching is not possible. It is more advantageous than other adhesives because curing takes place immediately. It is buff coloured adhesive, freely flowing and very smooth to apply. Its good water, alkali and oil resistance coupled with high bonding strength make it an excellent adhesive for all types of high bonding works in leather goods manufacturing.

### **Application:**

Surfaces to be bonded must be clean, dry and even. The adhesive is applied thinly and rapidly to both the surfaces and the coverage of adhesive is ensured completely and effectively. The solvent of the adhesive is allowed to evaporate till tack formation is felt. The glued surfaces are joined carefully and accurately avoiding air bubbles. The components are then pressed uniformly through out for perfect and accurate joining.

### **Demerits of permanent adhesive:**

As the bonding strength of the synthetic adhesive is very high, it is very difficult to separate the components in case of wrong assembly. Excess application of adhesive not only causes damage to the products but also stain to the linings. It is inflammable and produces toxic vapours and strong pungent smell. It is moisture sensitive.

## **(i) Lining:**

Lining is an important process. It is done in almost all leather goods. In lining, the lining pattern must always be bigger than the leather component pattern. When the lining is done, the excess lining can be trimmed off to achieve perfect lining. If the lining pattern and the leather component pattern are of the same size, there is every possibility of imperfect lining due to shrinkage of lining or due to inaccurate lining process. When lining, the adhesive is applied first to the surface of the leather component and care is taken that the adhesive covers the whole surface and the distribution of adhesive is uniform. The lining is then glued and then allowed to dry. Excess gluing must be avoided, as it may not only cause stains on the linings but also lumps. The glued lining is first fixed to one end of the leather component and then covered gently. The covering of the lining must be a continuous and steady process and the line of contact kept parallel to the meeting edges. Once the lining is done, the lined surface is rubbed with a smooth roller or a bone folder gently from side to side to press down the meeting surfaces and also to press out the air bubbles. The lined pieces are allowed to dry and checked for perfect lining. If there is any overlap of lining, the same is trimmed off with a sharp knife.

## Types of linings:

### Edge lining:

Edge lining is done on the edges of the component which gives softy feel to the products. Most pocket goods are done with edge lining (**Fig.6-19**).



**Fig.6-19 Edge lining**

### Full lining:

Full lining is attached to the whole surface of the component, using adhesive. The edges of the leather component are folded and then stitched. This lining gives firmness to the components. Most of the leather goods are done with full lining (**Fig.6-20**).

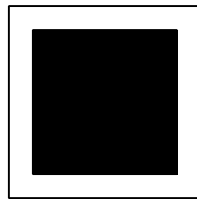

**Fig.6-20: Full lining**

### Drop-in- lining:

The lining is stitched first and then attached to the product on the top by stitching. The lining is held loosely inside the article. It is also called pull out or loose lining. This type of lining is done in most of the ladies handbags and stretch bags (**Fig.6-21**).

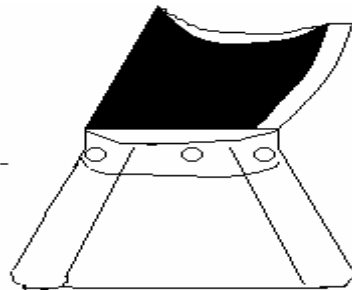
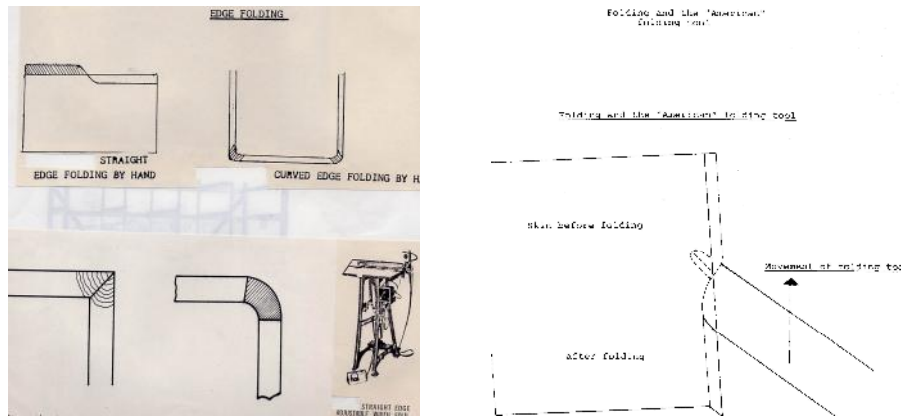

**Fig.6-21: Drop-in-lining**

### (j) Edge folding:

Edge folding is done during the fabrication of leather goods. Most of the leather goods are made with folded edges or turn over edges. It is a process of folding the leather uniformly along the edges to a predetermined width either in straight lines or in curves. The folding is done to improve the edges and to enhance the beauty of appearance. The

skived edges are coated with adhesive and then with the help of a bone folder or a scale, the edge is folded along the entire length of the leather component. Folding is done over the lining or foam or reinforcement material. The folding must be done accurately, skilfully and perfectly so that in the subsequent operation of stitching, there will not be any problem. In folding, the straight edge folding is done first and then curved corners. The curved corners require hairline cuts for perfect curved folding (**Fig.6-22**).



**Fig.6-22 Edge folding of components by hand and treadle operated machine**

In case of bulk production, folding of the components is done in the straight edge-folding machine. Folding to any desired width can be obtained by adjusting the guide plates .In certain articles, folding and creasing can also be done in the edge folding and creasing machine (**Fig.6-23**).

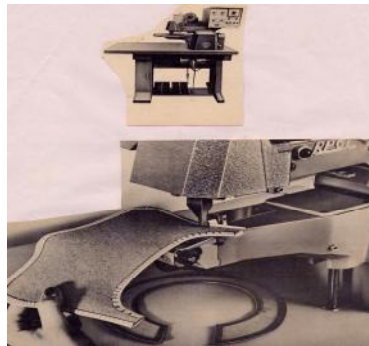

**Fig.6-23: Edge folding of components by machine**

**(k) Gussets making:**

Gussets are determined by its holding capacity of leather goods. Gussets are inserted where spaciousness is required. Articles, with proportionate gussets assembled in right way and stitched properly, give well out look and serve for a long time. Gussets are made in a variety of types and commonly used gussets in leather goods making are side gussets,

continuous gussets and folded gussets. Gussets are also made with different types of gusset joints.

**Side Gussets:**

Side gussets are joined at the sides of the article e.g. ladies handbags, shopping bags, duffel bags, medical representative bags, etc.

**Continuous Gussets:**

Continuous gussets are joined at the sides, top and bottom of the article e.g. air bags, shoulder bags, wrist pouches, shaving kit bags, ladies hand bags, etc.

**Folded gussets:**

Folded gussets are joined at the sides and bottom of the article e.g. document cases, file cases, portfolio bags, clutch bags, ladies handbags, etc.(Fig.6-24).



**Fig.6-24: Types of gussets**

**(I) Handle making:**

A wide range of handles is fabricated in leather goods making. Lighter handles are used in box work constructions like jewel boxes, cosmetic boxes etc. Heavier handles are used in heavy and luggage goods like briefcases, document cases, travel cases, instrument cases etc. Different constructions are used for making a variety of handles such as round handles; flat handles and shaped handles to suit to the designs of the articles (**Fig.6-25**).

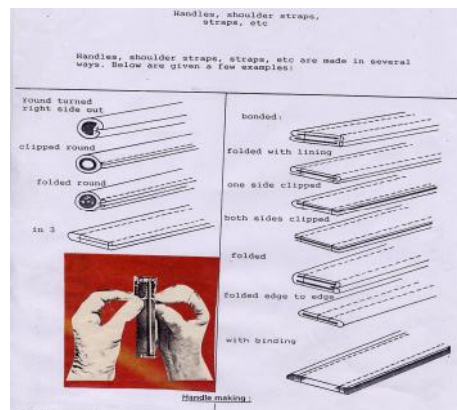

**Fig.6-25: Types of handles and handle stitching**

**(m) Frame fixing:**

Frame fixing is done in ladies framed purses and handbags. Frames are available in different sizes and shapes with high glossy finish of chromium plating or brass plating. Suitable frames are selected for the products and fixed either manually or mechanically. In the manual process, framing tools are used for fixing frames. As frame fixing is considered to be a very high skill job, it is always done only by highly skilled technicians. After preparation of components, the prepared components are checked for quality and then sent for assembling process.

**Assembling processes:**

In the process of assembling, the prepared components are assembled part by part. The assembled components are then joined to give a shape to the article. In assembling process, different techniques of constructions are used depending upon the types of articles to be manufactured (Fig.6-26).



**Fig.6-26: Assembling process**

## Types of construction:

In leather goods manufacturing, different techniques of constructions are used for making leather goods. Most commonly used constructions are: a) cut edge construction, b) turnover-edge construction (fold-edge construction), c) turn-edge construction (stitch and turn construction), d) butt-edge construction, e) moulded construction, f) built-up construction, g) box-work construction, h) limp construction, i) semi-limp construction, j) stiffened construction and k) edge construction.

### (a) Cut-edge construction:

The components are cut to definite sizes of the product and assembled. In this type of construction, the cutting edges are seen. The edges are flush or level when stitched. The edges are stained with the matching colour of the product to improve its elegance. The edges are creased and wax polished. After wax polishing, the edges are rubbed with a piece of smooth cloth or circular slicker to get glossiness of the edge. Good cut-edge work depends upon the edge being cleanly cut and the crease line being bright and shiny. E.g. coin purses, wallets, under-arm cases, gents' belts, shoulder bags pilot chart bags, document cases, etc (Fig.6-27).



**Fig.6-27: Cut-edge construction**

### (b) Turn-over edge Construction: (Fold-edge Construction):

In this type of construction, the leather components are cut with allowances for folding. The edges are skived to a suitable thickness for easy and perfect folding. Turnover or folding is done over the lining or reinforcement and then stitched. This encloses all raw cut-edges. This construction imparts greater durability and elegance to the products. E.g. wallets, passport covers, gent's belts, ladies handbags, portfolio bags, etc (**Fig.6-28**).



**Fig.6-28: Fold-edge construction**

**(c) Turn-edge construction: (Stitch and turn construction):**

Turn edge or stitch and turn edge construction is very popular and extensively used in leather goods making. The stitches in the article are not seen outside. During assembly, the components and piping are assembled with inside out (flesh side out) and stitched. When stitching is over, the right side (grain side) of the article is pulled out. So, the stitches are seen only inside and the piping is seen outside. The piping on the seam adds strength and beauty. E.g. wrist bags, ladies handbags, air bags, shopping bags, etc. (Fig. 6-29).



**Fig.6-29: Stitch and turn construction**

**(d) Butt-edge construction:**

In butt-edge construction, two turned over edges are joined together, keeping the grain side out and stitched. It gives a double edge with stitches on all round the edges. E.g. spectacle cases, framed handbags, shoulder bags, document cases, etc. (Fig.6-30):





**Fig.6-30: Butt-edge construction**

**(e) Moulded construction:**

Moulded construction is used to project glassware, flask etc. Only vegetable tanned leather is moulded to any desired shapes and they only retain the moulded shapes. Vegetable tanned leathers of even thickness are wetted and wrapped round the mould of desired shape of an article and allowed to dry completely. In some cases, the leathers are pressed under a male and female mould to get the desired shape and dried. After drying, it would retain the shape of the mould. Then the joints are well secured by using adhesives or stitches e.g. water bottles, camera cases, cigar cases etc. (Fig.6-31).



**Fig.6-31: Moulded construction**

**(f) Built-up construction:**

In built-up construction, a strong yellow straw board is used as a foundation for the article to be made. The yellow straw board is moistened using water and sponge evenly. It is then wrapped round the wooden mould. After drying, the foundation of the article is built up with millboard and leather (with or without foam) using adhesive and finished.

The inner lining of the article is built up with the paper and lining leather or silk using adhesive. E.g. penholder tumblers, pincushions, pencil trays, letter paper cases, visiting card cases, etc. (Fig.6-32).



**Fig.6-32: Built-up construction**

**(g) Box-work construction:**

In box-work construction, wooden frame or box of required sizes is made first from lightwood like pine wood, ply wood, deal wood etc. Since the wooden surface is coarse, it is covered with millboard to give an uniform and smooth surface. Foam and leather are fixed over the board using adhesive. Foam is given for giving cushioning effect. The metal hinges or leather hinges are used to join the top and bottom lids. The fittings such as handles, locks, rivets etc are fixed. The inside of the product is lined either with suede or fabric or silk or imitation suede or synthetic fabric with foam as a backing material. Load bearing parts are fixed with studs to overcome wear and tear. The fittings should be well riveted to carry or hold the intended weight for which it is meant, e.g. brief cases, jewel boxes, cosmetic boxes, card cases, etc. (Fig.6-33).



**Fig.6-33 Box-work construction**

**(h) Limp construction:**

Some leather goods are made without any internal stiffening or reinforcement. These types of leather goods are known as limp leather goods. These leather goods are flexible and soft because only leathers and linings form the products. E.g. coin pouches, wallets, ladies purses, etc.

**(i) Semi - limp or semi stiffened construction:**

Some leather goods are made with paper or stiff fabric material as a foundation between the leather and lining. This type of construction imparts a degree of firmness but not minimizing the flexibility of the goods. These leather goods belong to semi-limp or semi-stiffened leather goods. Most of the ladies handbags and inside pockets of the leather goods are made using this technique.

**(j) Stiffened Leather construction:**

Some leather goods are made with a foundation and over which paperboard and leather are fixed using adhesive. Such leathers goods are quite stiff and so they are called stiffened leather goods. E.g. suitcases, brief cases, cosmetic boxes, jewel boxes, etc.

**(Fig.6-34)**

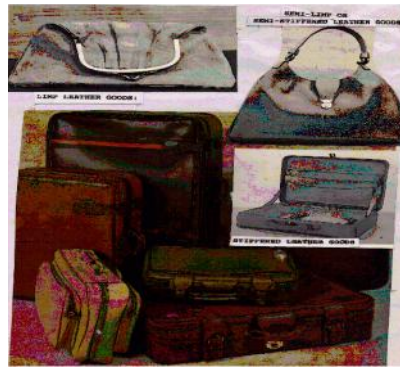

**Fig.6-34: Stiffened leather goods**

**(k) Edge construction:**

Leather goods are fabricated with different types of edges according to the designs. They are i) raw edges, ii) folded edges, iii) bound edges, iv) bound edges with binding, v) bound edges without binding, vi) straddled edges and vi) mixed edges.

**(i) Raw edges:**

The leather components are stitched with its raw edges seen e.g. spectacle cases, gent's belts, wallets, key cases, document cases, shoulder bags, etc.

**(ii) Folded edges:**

The leather components are turned over or folded over another leather or lining and then stitched. This covers raw edges e.g. wallets, passport covers, handbags, portfolio bags, ladies handbags, etc.

**(iii) Bound edges with binding:**

Two leather components and piping are attached with its flesh sides out. After stitching, the components are turned to grain sides. Only piping is seen and stitching is not seen e.g. ladies handbags, shoulder bags and softy types of articles.

**(iv) Bound edges without binding:**

Two leather components are stitched with its flesh sides out and then turned to its grain sides so that the stitches are not seen e.g. coin pouches, softy ladies purses, etc.

**(v) Straddled edges:**

Two leather components are covered with a piece of leather strap as piping and then stitched. This covers raw edges of the components e.g. shopping bags, school bags, folio cases, shoulder bags, etc.

**(vi) Mixed edges:**

One leather component is folded and attached with an unfolded component (raw edged component) and then stitched. This sees mixed edges e.g. gent's belts, shoulder straps, etc. (Fig.6-35).

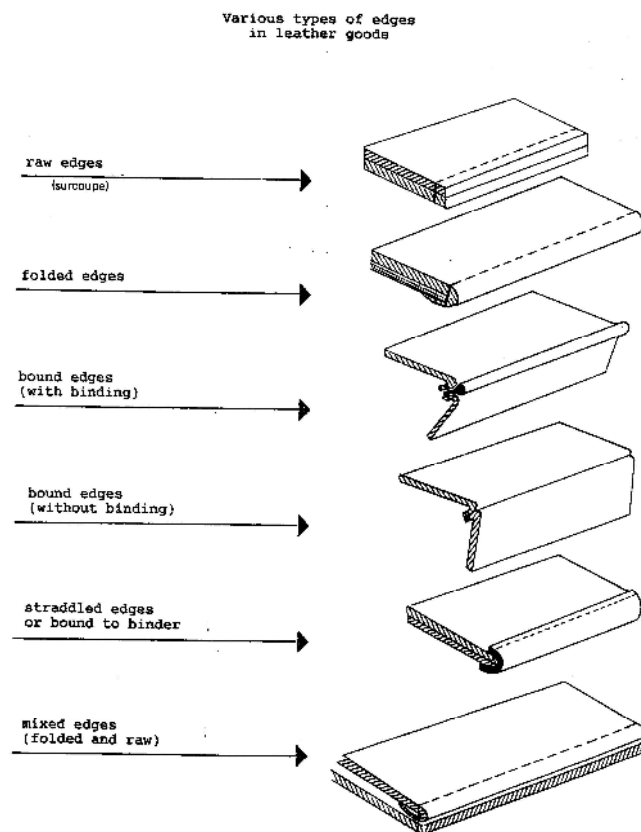

**Fig.6-35 Types of edges**

## Types of joining:

### Seam joining:

Seam joining of leather piece is a common feature in leather goods making. Since leather is having an irregular shape, it is very difficult to get a long strap. It is therefore necessary to cut leathers into pieces and join for making gussets, piping straps, shoulder straps etc. Moreover, the cost of leather is very expensive. In order to bring down the cost of leather products and maximize the cutting value, it is necessary to cut leather into pieces and join. Joining of pieces is done using various techniques.

#### i) Astride seam:

In astride seam, one of the pieces comes on top of the other and a seam attaches all these together.

#### ii) Piped seam:

A piping is done on the first piece on the grain side. A second piece is then fixed against the piping. The finished seam is identical to a simple seam with the piping in the middle.

#### iii) Blind seam:

The seam is made invisible by tapping the top piece on the bottom piece. For this, an underlay must be done on the bottom piece (Fig.6-36).

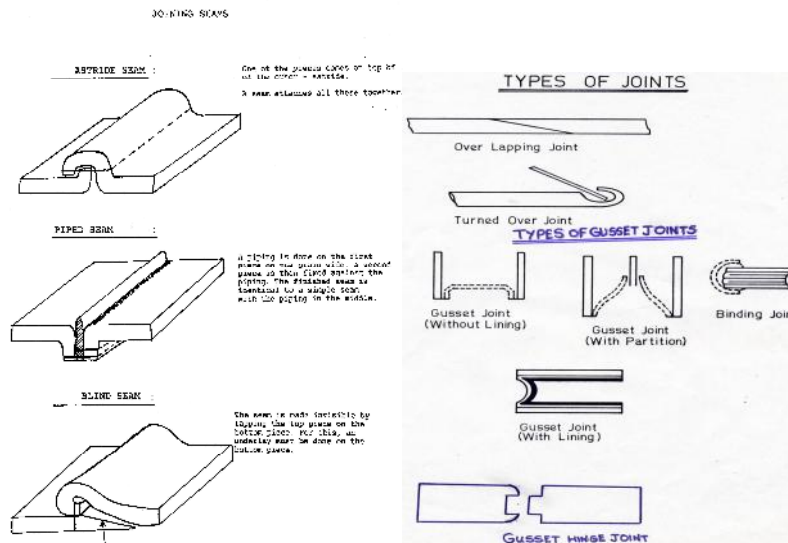

Fig.6-36: Types of joining

After assembling, the assembling of the components are checked for quality and then sent for stitching operations.

### Stitching processes:

In the process of sewing, sewing is the most important operation, which decides the quality of the end products. The highly skilled stitchers who are well versed in operating various types of sewing machines do sewing. Sewing the finished products are carried out in flat bed sewing machine or cylinder bed sewing machine as the case may be. Stitching thread should have good tensile strength, abrasive resistance to moisture, heat and ability to withstand oils, solvents and adhesives. A correct thread for specific use is essential to achieve efficient production. Commonly used threads are cotton, nylon, nylon cotton, and polyester cotton. Before stitching of the products, the stitches are tested on a piece of leather. If necessary, suitable adjustments are made for perfect stitching.

In stitching leather products, two types of stitches are commonly used. They are lock stitches and chain stitches. In lock stitches, the thread from the needle and bobbin lock together and fix firmly in the material. In chain stitching, the stitch is formed by single thread. It is not as strong as lock stitches. When the thread breaks, the seams become weak. The products are stitched care fully. After stitching of the products, they are checked for quality of stitching and then sent for finishing (**Fig.6-37**)

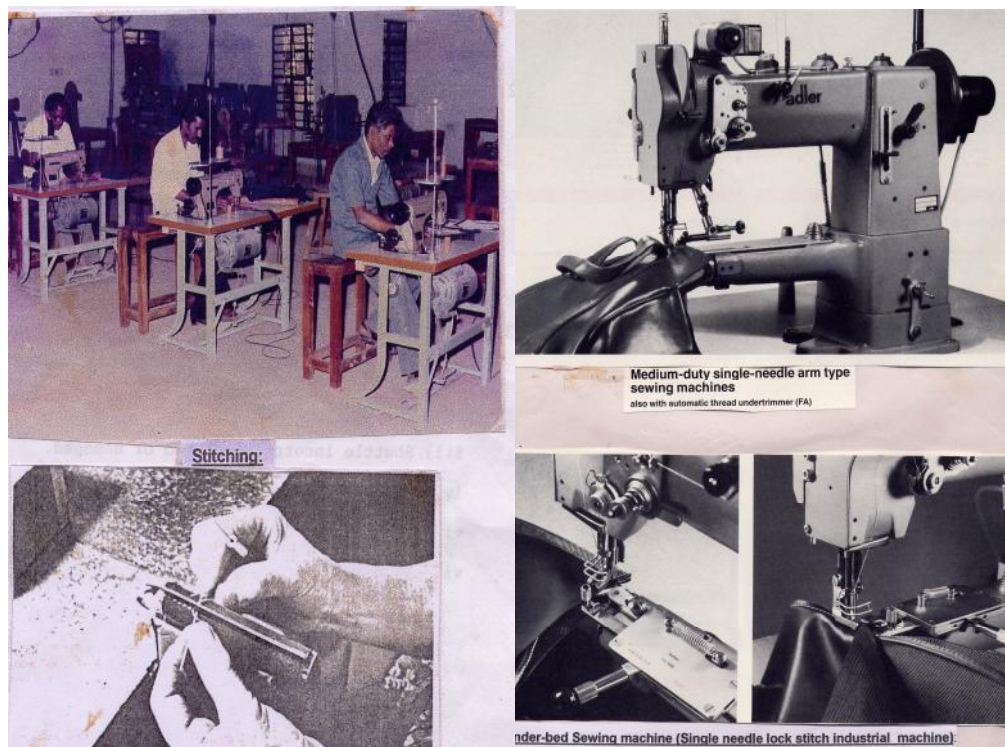

**Fig.6-37: Machine and manual stitching**

#### **Finishing processes:**

Finishing is the final process in the manufacture of leather goods. A team of semi-skilled technicians and helpers headed by a quality control supervisor does finishing. After



stitching, the articles are checked carefully. Excess thread is removed by fusing with a soldering tool. Excess adhesive is removed with a piece of crepe rubber sheet. The whole product is cleaned both inside and outside with a clean piece of cloth. Before the articles are sent for packing, strict quality control is observed for perfection in assembling, stitching accuracy and smooth functioning of fittings (**Fig.6-38**).



**Fig.6-38: Finished leather goods**



# Chapter 7

## Leather Craft Works

Leather craft works combine world charm of heritage designs and timeless artefacts with a modern practicality to create a whole new classic but updated look. Leather craft work has two characterizations: i) it lends itself to an enormous variety of both useful and decorative products which are a need and an asset in modern living and ii) it affords a larger choice of interesting articles that will bring beauty. There are several types of leather craft works, which include carving, embossing, stencilling, batik, pokerwork etc.

### Carving:

Carving is done on moistened vegetable tanned leather using a variety of designed tools. The components are cut and the designs are carved on each component to bring about variety, harmony and beauty. The illustrations of craftwork are as follows:

### Moistening:

The leather is moistened using water and sponge on the flesh side evenly. The leather is turned over and the grain side is dampened. If some areas begin to dry, dampening is done again over these areas to make them fit for carving. If the leather is too dry, it will be hard to cut with the swivel knife. If the leather is too wet, the cuts will not be prominent. So, by wetting the leather properly, the carving cuts could be got prominently (Fig.7-1).

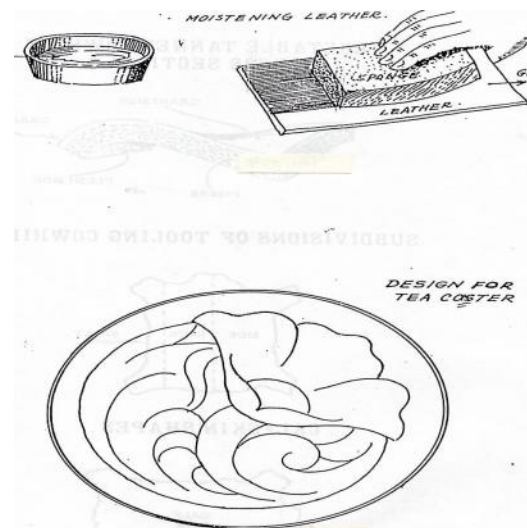
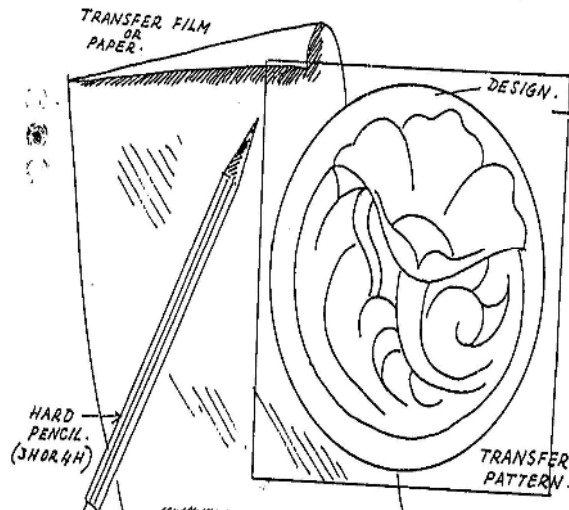

Fig.7-1: Moistening of leather

### Transfer of design:

A transfer pattern is first made by tracing a design (for e.g. flower) indicating the lines to be cut with the swivel knife (**Fig.7-2**).



**Fig.7-2: Transfer pattern**

### Making of pattern:

A piece of transfer film is placed over the leather and fixed using adhesive tape. The lines of the design are retraced by means of a blunt and smooth pointed tool. Before the pattern is removed, the leather piece is checked for perfect transfer of design.

### Leather craft works by crafting tools:

Work done on lighter weight leathers is generally known as tooling and stamping. Work on heavier leather is called carving and can be augmented with stamping. The tools for both are pretty much the same, except that swivel knife is used only for carving. The tools needed to start with are a rawhide maul or mallet. Swivel knives come with interchangeable blades for use on various types of leathers. Tracing and modelling tools are used to transfer and deepen the designs to be tooled onto the surface of the leather. They come with two heads, one smaller than the other, but both of identical shape. The basic modelling tool is to transfer of designs. The deer foot modelling tool is for deepening outlines. The ball end-modelling tool is used for embossing. Stamping tools are available in numerous categories, shapes and sizes. The handle of the tool remains the same but the tip is changed for each different impression (**Fig.7-3**).

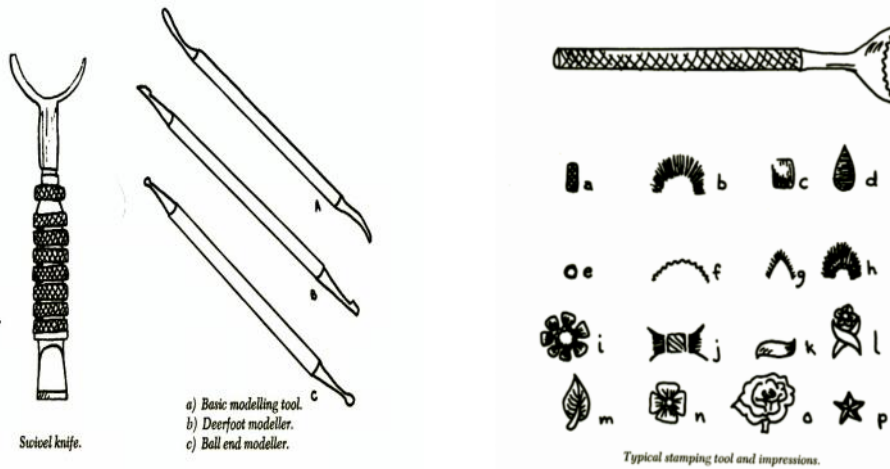

**Fig.7-3: Carving tools**

**Rawhide Mallet:**

Rawhide mallet is used for drive punches and other tools. It should be noted that lightweight hammer is not a substitute for a rawhide mallet as it will drive the stamping tools too far into the leather surface and result in deep impression (Fig.7-4).

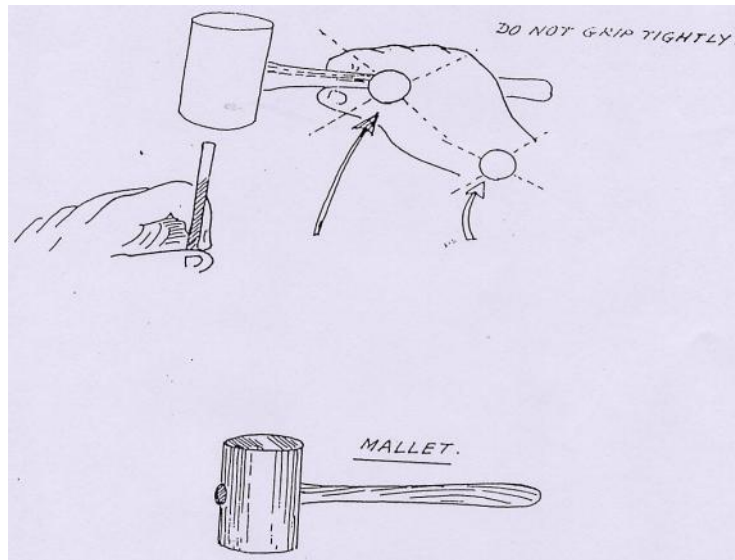

**Fig.7-4: Raw-hide mallet**

### Camouflage:

The camouflage is a half-moon shaped with two sharp heels and has a rounded serrated face that slopes towards the toe. The serration fans out from a central focal point into a sunburst effect. The purpose of the tool is to texture certain areas of the pattern thereby adding beauty and flow of the design (**Fig.7-5**).

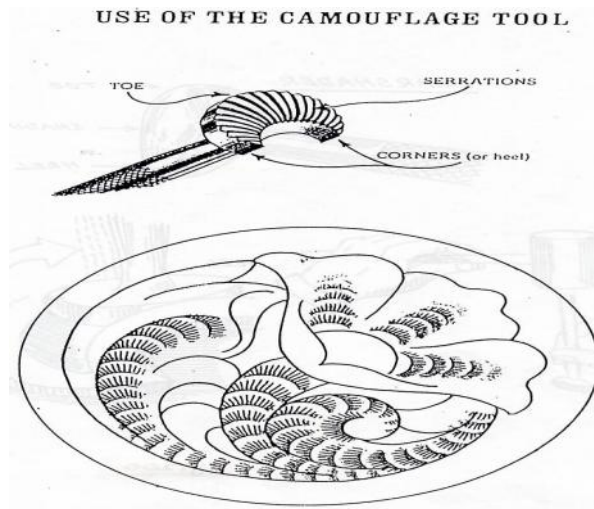

**Fig.7-5: Camouflaging**

### Pear shade:

Pear shade is used for making a 3D effect in design. The tool shades areas outlined by the swivel knife. The shade depresses areas away from that lines gives in shaping flower, petals, leaves etc in a realistic manner. The shading operation burnishes the leather to a rich and dark contrasting colour. The depth of the impression and darkness of colours are controlled by the force of the stroke of the mallet (**Fig.7-6**).

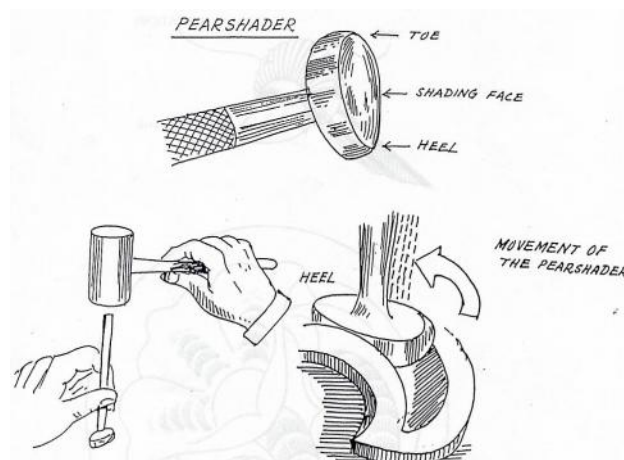

**Fig.7-6: Shading**

**Beveller:**

Beveller brings a raised effect by depressing outlines. The bevelling surface of the beveller slopes towards the heel. The deepest part of the bevel is usually next to the cut line of the design with the sloping bevel fading towards the background areas. When the beveller is struck with the mallet, the leather is compressed and a depth is created. This results in burnishing of leather and giving a contrast to the design (**Fig.7-7**).

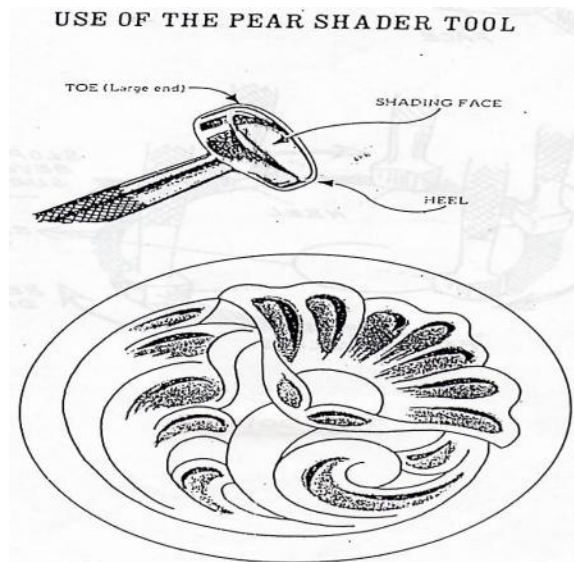

**Fig.7-7: Beveling**

**Veiner:**

Veiner is used to produce veins to leaves. It may also be used to produce other decorative and special effects. When veining leaves, the impressions should be spaced evenly. Leaning the tool to a greater degree makes the deepest part of the impressions. As the leaf widens, a broader impression is desired and the tool must be brought to a more vertical position. It adds accents to leaves and other similar parts of the design (**Fig.7-8**).

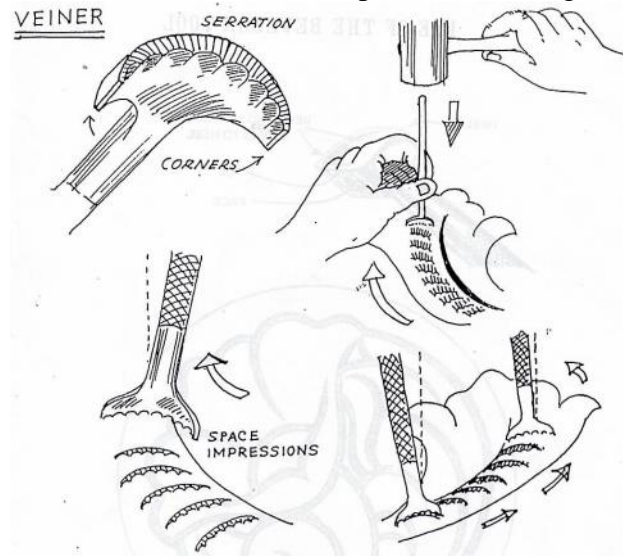

### Fig.7-8: Veining

#### Seeder:

The seeder is used for making seed pods in the flower centre. An outer row of seeds is stamped first. The second row of seeds is stamped close to the first row and keeping them as even as possible. Overlapping must be avoided. The remaining area is filled with seeds and stamped carefully (**Fig.7-9**).

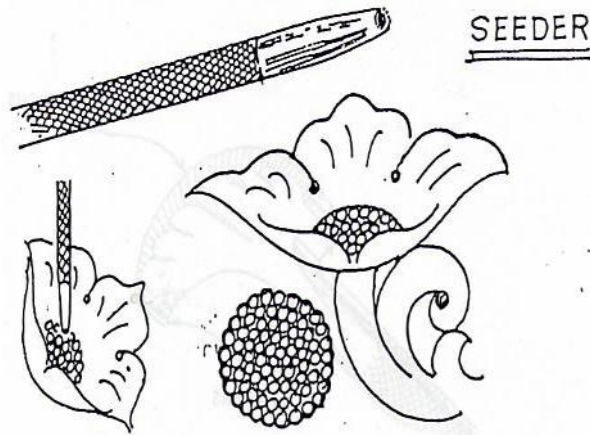

Fig.7-9: Seedpods

#### Background tool:

Background tool is used to match down the background within and around the design. It is the most important tool in leather craft because it makes the design stand out in bold relief. Background tool can be used on both large and small areas. A small pointed end is needed for narrow areas. In very small areas, the tool can be leaned towards the point keeping the heel from touching a raised portion of the design. The background tool is used in the same way as the beveller and made to walk on the design (**Fig.7-10**).

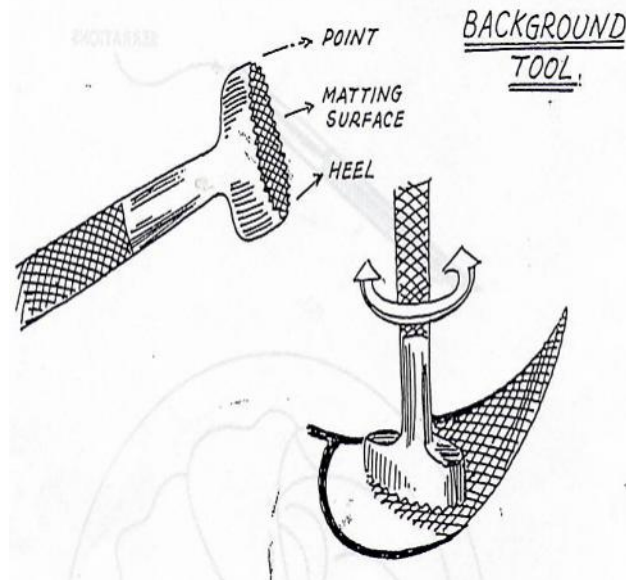

Fig.7-10: Background designs



**Swivel knife:**

Swivel knife consists of a blade, barrel, stem and yoke. The knife is placed on the work surface. The holding of the knife is illustrated in the fig.- the index finger on the yoke, thumb holding lower part of the barrel, little finger holding the blade and other fingers holding the barrel. The blade is raised slightly from the leather and the barrel of the knife is turned back and forth with the fingers. The blade is pressed on the moistened leather with pressure. An even depth of the lines is maintained throughout (Note: cutting depth for outlines of designs is approximately one – half the thickness of the leather) (**Fig.7-11**).



**Fig.7-11: Decorative cutting by swivel knife**

**Caution:**

Undercutting must be avoided while doing carving as the blade cuts under the surface of the leather on one side of the cut, leaving a thin, raised, undesirable edge. This makes it difficult to use the stamping tools in further operations to follow and also distorts the design to some extent, depending upon the details of the design. Depth and length of cuts are made with one motion. Re-cutting of any lines to make them deeper or to correct the flow must be avoided. A properly sharpened blade will produce easier and smoother cutting, less fatigue and better results.

**Stropping the blade:**

The bevelled cutting sides of the blade should be stropped during cutting operations. Stropping the blade polishes the sides and keeps the blade cutting smoothly. The bevelled side of the blade must be flat against the polishing surface. The knife is held firmly and pulled in one direction only and the blade is always pulled across the polisher (**Fig.7-12**).

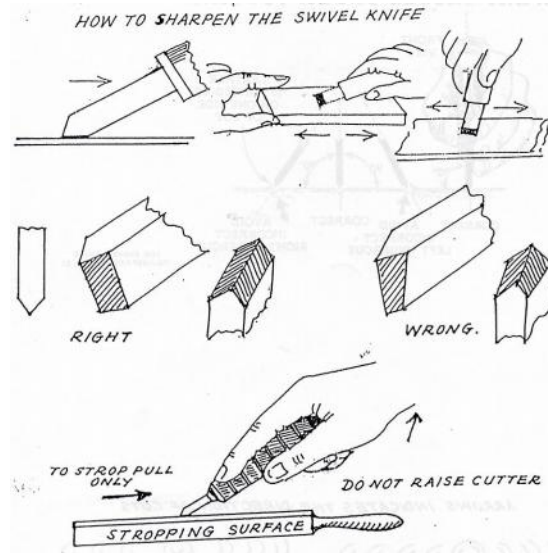

**Fig.7-12: Stropping the blade**

**Making decorative cuts:**

Decorative cutting is done with swivel knife after all other carving and stamping works have been completed. It is the final step in adding ornamental details to the design. Good decorative cutting adds greatly to the attractiveness to a carved design (Fig.7-13).

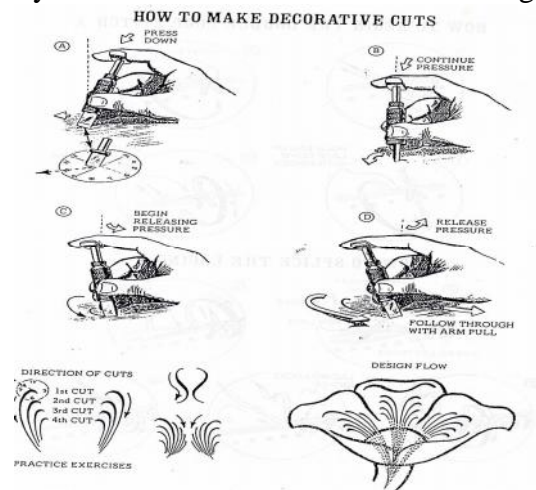
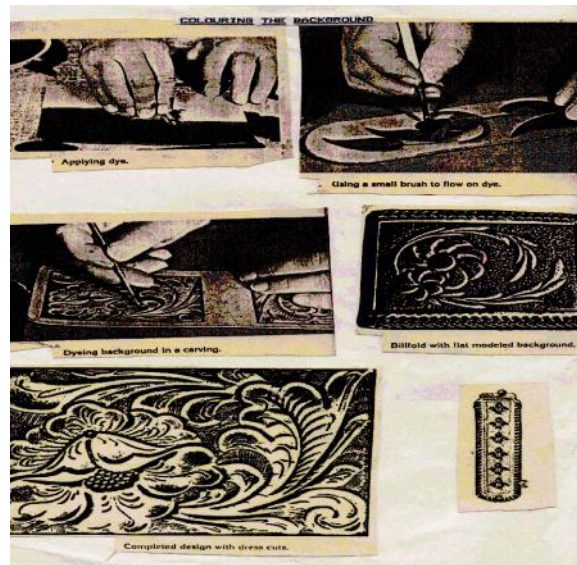

**Fig.7-13 Decorative cuttings for carving designs**

**Colouring of the background:**

The design can be coloured beautifully with the proper application of suitable dyes. By colouring the design to the different tones, enhances the beauty of the design and also toning up the background area and the main designed motif. The unique hues and designs achieved are a constant source of pride and individuality. To colour leather that has been carved, it should first be cleaned with the cleaning fluids available or a solution of oxalic acid, made by mixing acid crystals into one quart of water. The solution is then brushed onto the leather with a sponge and allowed to dry. The suitable dye is spread quickly and

evenly across the surface of the leather using sheep's wool puff or cheese cloth. To dye backgrounds or highlight design parts on carved leather, the leather is cleaned and dyed with a small brush (Fig.7-14).



**Fig.7-14: colouring designs**

#### **Finishing:**

Raw edges are dyed with a felt or lamb's wool dauber. For protecting from dust or moisture, the surface of the leather has to be coated with wax polish or lacquer. The design gives more relief effect due to shining.

After carving is done, the components are cut with patterns and assembled into a variety of products like wallets, key cases, coin purses, ladies pouch bags, spectacle cases, comb cases, wall hangers, etc.

#### **Process of lacing:**

In making leather craft articles, the process of lacing or thronging is perhaps the most attractive, and certainly the strongest, method of attaching leather seams. Laces lend themselves well to almost any article or style and are not limited to one method of stitching. There are several stitch patterns to choose from, each is different in appearance and application. Laces can be bought on spools. They usually come in black, brown, white and several natural tans. They are made of calfskin, goatskin or cow hide. The width and weight of laces vary and should be selected with regard to the size and type of leather article to be laced. Marking the holes for laces is an important step and the marks for the seam are made either by stitch gauge or thronging chisel. Using a single prong thronging chisel or a three-prong chisel does punching holes for lacing (Fig.7-15).

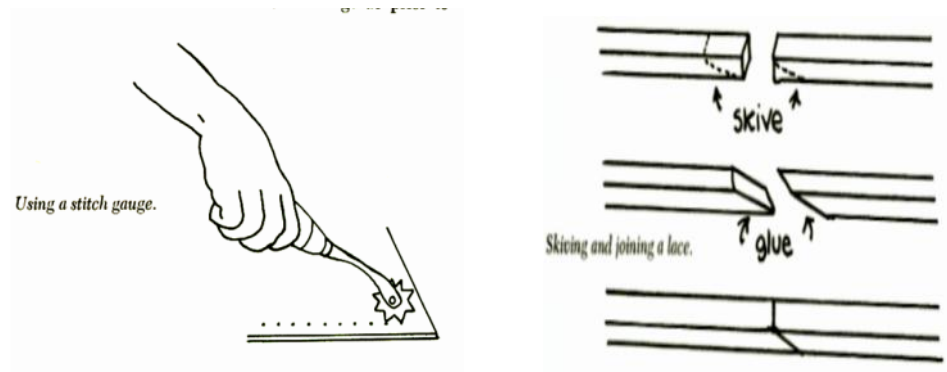
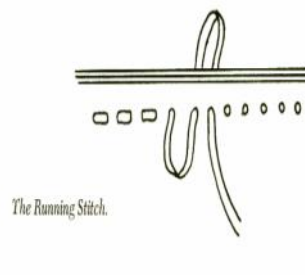

**Fig.7-15: Process for lacing**

**Lacing stitches:**

**(i) The running stitch:**

This is a simple in and out stitch. The lace should be skived a bit at one end and put in the lacing needle. The other end is skived and glued with rubber adhesive to the inside of one seam as close to the holes as possible. The needle is then brought through the hole and the running stitch continued by going in the next set of holes and out the following set. When the end is reached, pull the lace between the two pieces that make up the seam and cut it off after leaving about 1-1/2" excess which will be then glued as close to the holes as possible (**Fig.7-16**).



**Fig.7-16: Running stitch**

**(ii) The whipstitch:**

This is done by putting the lace in a needle and gluing the other end near the inside seam as with the running stitch. The needle is then brought from the back into the first hole, out the front, over the seam and into the back of the next hole. When a corner is reached, two stitches are made in the hole just before the corner and then two in the hole of the corner itself. This technique will cover the corner properly and add strength for longer wear (**Fig.7-17**).

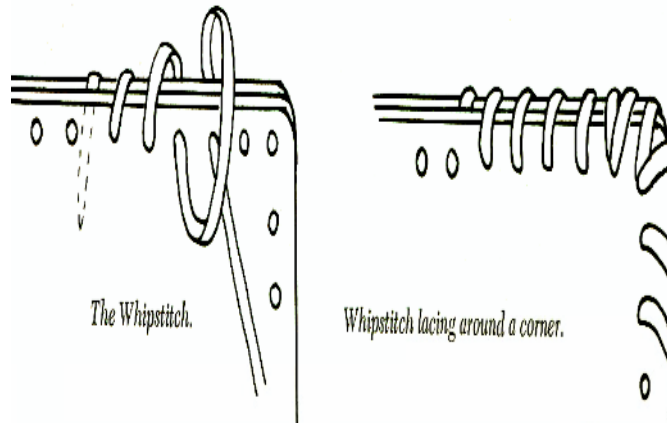

**Fig.7-17: Whipstitch**

**(iii) The Florentine lace:**

This type is done with a softer, wider lace that covers the edges of the seam while doing a regular whipstitch. It is the width and texture of the lace that gives it a different look. It folds up as it goes into the holes and widens as it covers the edges of the seam. Since the Florentine lace is softer, lacing in the corners without difficulty either by two lacing or three lacing in the corner hole (**Fig.7-18**).

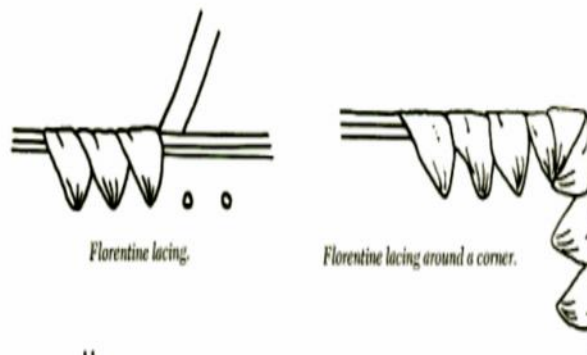
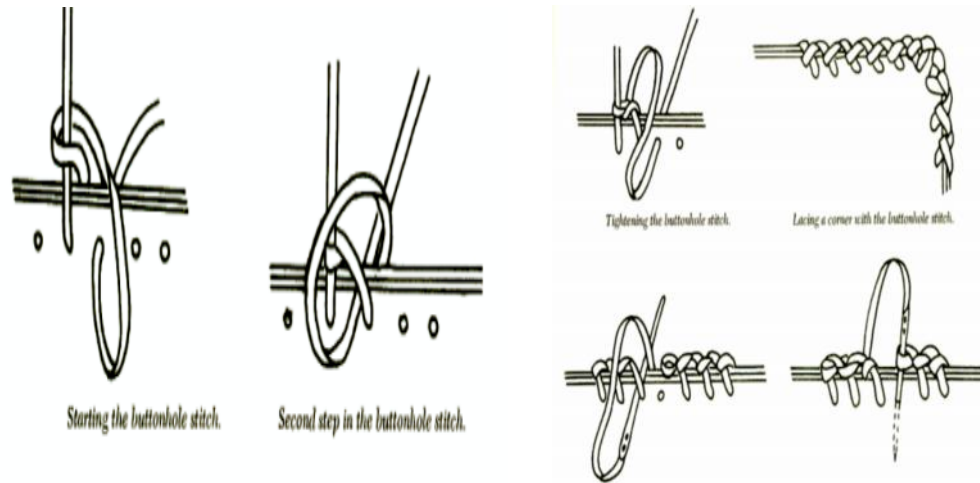

**Fig.7-18 Florentine lacing**

**(iv) The buttonhole stitch:**

It is a more complicated lacing method. It is started by lacing needle, bringing it through the first hole and leaving a three-inch piece of lace sticking up. The laced needle is then brought from the back and the lace is wrapped once around the three-inch piece. The needle is then put into the second hole and through the stitch made just above the second hole. Then it is tightened. In the corners, the stitch can be laced either two or three times into the corner hole. To finish, lace it up to the first stitch and then carefully undo the first stitch leaving a loop. The piece that is left should be pulled through at the back in between the two pieces of leather that form the seam and cut off leaving 1-1/2" for gluing close to the other stitches. The last stitch is then completed by going through the loop left by the first stitch and into the first hole. The remaining lace is then pulled between the

two pieces of leather and cut of to 1-1/2” and glued right next to the other glued end of the lace (**Fig.7-19**).



**Fig.7-19: Buttonhole stitch**

**(v) The double cross stitch:**

This is very attractive lacing technique that uses two laces at the same time. Start by gluing the two laces ends right near the inside of the holes and put the other ends into two lacing needles. Draw the lace through the first hole and leave half the length on each side of the leather. The stitch is done by putting the needles through the same hole, either both at once or one at a time. Then they are crossed over the edge of the leather and inserted into the next hole. This makes a very sturdy seam. Going into the next hole can make a quicker cross-stitch so that the stitches look the same from top and bottom, like series of X's with a space between each one. After finishing lacing, gently hammer the completed seams with a mallet to flatten them (**Fig.7-20**).

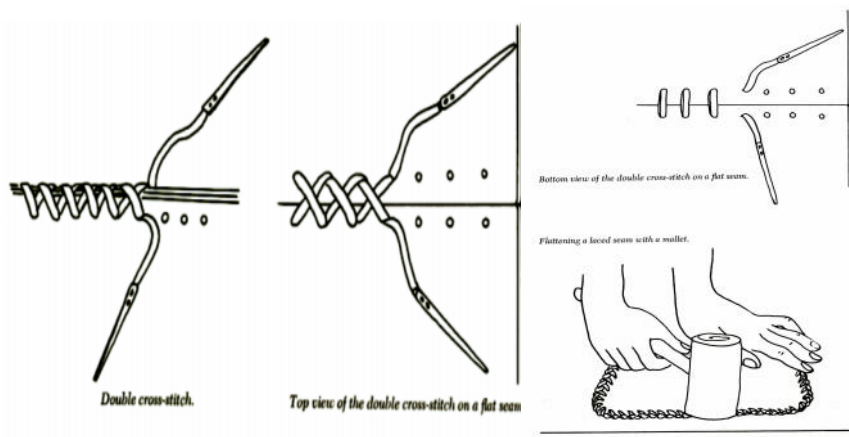

**Fig.7-20: Double cross stitch**



### Embossing:

Embossing is done on moistened vegetable-tanned leathers with engraved design blocks. The embossing machine with suitable heat and pressure does the embossing. The components of the articles are cut and then embossed with designs. The embossed components are then assembled and fabricated into products like wallets, coin purses, shoulder bags etc. (Fig.7-21).



**Fig.7-21: Embossed leather goods**

### Stencilling:

Stencilling is done by incising with a sharp knife on the finished surface of leather components. The incised components are lined with matching colour linings, which must be subtle and coordinating with the incised components. The stencilled components are assembled and made into colourful products like jewel boxes, handbags etc. (Fig.7-22).



**Fig.7-22: Stencilled leather goods**

**Batik works:**

Batik works display rich intricate skills and graceful floral designs in magnificent colour combinations. It is done on vegetable tanned leathers. A skin is pressed in cold condition by the embossing machine. The Arabic gum is applied on the whole surface of the leather and dried in the sun. After drying, the glued surface is cracked by pressing the leather in different directions. Spirit soluble dies do colouring, which penetrates through the cracked portion. The gum is then removed by washing with water. The alternate process of masking and colouring the surface of the leather can bring different colour combinations. The leather is given a final touch with the brush and then lacquered. The batik leathers made are then cut into components and assembled into products like wallets, passport covers, jewel boxes, etc.(**Fig.7-23**).

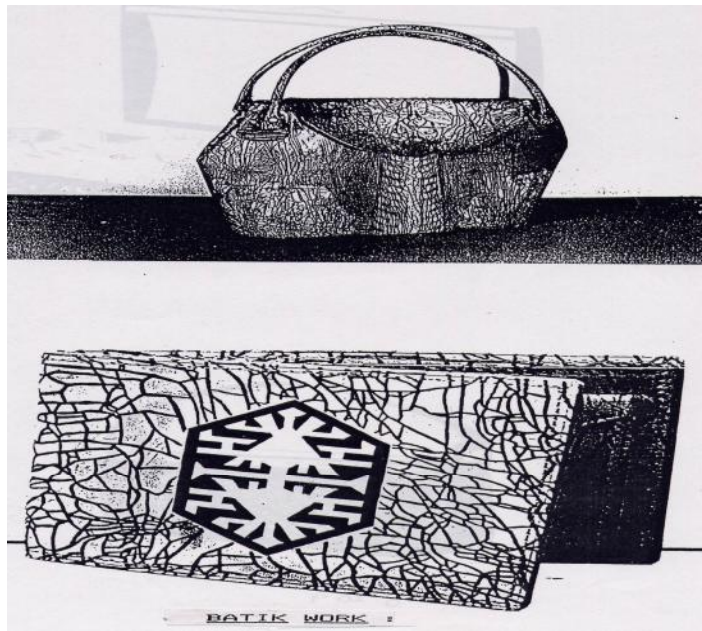

**Fig.7-23: Leather goods with batik work**

**Pokerwork:**

Pokerwork is done on moistened vegetable tanned leathers. The components of the articles are cut and fascinating floral designs are drawn on the moistened components using tracing tool. These are then finished with a heating tool. The components are then assembled and made into products like card cases, cigar cases etc. These articles come in array of designs in exciting colour combinations (**Fig.7-24**).



**Fig.7-24: Leather goods with pokerwork**

# Chapter 8

## Quality Control Aspects

A simple definition for quality and control are:

**Quality** - Meet specification, fitness for use, anything that can be improved, absence of variation, conformance to requirements and bad quality is a social loss.

**Control** - preventing defects from happening.

Quality control is a system of integrating quality development, quality management and quality improvement. It aims at production of only quality products. For effective quality control, it is necessary to exercise control over the input of materials, process, employment of skilled labourers, management techniques and use of appropriate tools, equipments and machines. Quality control results in elimination of material wastes and ensures in quality product and full customer satisfaction. The subjective definition of elements of quality relates to th design, style, colour and aesthetics. Objectively, quality is the ability to meet consistently the return and clearly stated specifications. These are aimed at producing a product suitable for end use and price. The competition in the world market has become tough and if a country has to compete effectively in the world market, the products supplied must be of consistent in quality, colour, feel and prompt delivery. Achieving required quality and at an acceptable level of productivity are basic requirements for success. Quality of products can ensure prosperity to the producer by increasing returns, to the consumer with a better product at a price and to the nation with the additional foreign exchange. Quality of any product is determined by judicious application of various inputs such as fittings, embellishments, modern techniques of fabricating, sophisticated tools, equipments, machines and highly skilled artisans.

### **Quality control aspects of leather goods manufacturing:**

#### **Quality management:**

In quality management, the management must have a considered policy for quality and then make sure that all employees understand it. Supervisors play an important role in workers motivation and in quality control. Though supervisors do not usually spend much time in checking quality, they have a large influence on the level of quality. Leather goods or parts returned by examiners for repairs or replacements should always be routed through supervisors rather than directly to the workers concerned. This enables the supervisor to assess the accuracy of the quality team as well as being aware of shortcomings in the staff. If workers are motivated to increase output by payment by result schemes, this may be at the expense of quality if the incentive scheme is not designed or implemented properly.

**Specifications:**

Written specifications are essential to ensure that the buyer and seller both understand exactly what is to be manufactured. In many cases, “specifications” are informal. The term “commercially acceptable” is frequently encountered but unfortunately, it does not tell the leather goods maker what standards his product should conform to or the leather goods producer what the leather characteristics should be. Formal specification results in the company being control of the whole operation.

**Stage specifications:**

- Agree with the customer the specification of the leather goods he wants
- Translate this into the company’s technical terminology
- Define specifications for raw materials and accessories
- Define specifications and tolerances for each stage of leather goods production
- Complete the quality manual entry form for the leather goods in question

Specifications must be agreed between the parties concerned, be the buyer and seller or cutting room and sewing room. Specifications, which are too tight, can make the product more expensive than it need be. If they are too loose, they are unlikely to fulfil their objectives. An important aspect of specification is that limits of acceptability are established. Tolerances must be established in such a manner that measures falling outside the tolerance are clearly unusable and must be rejected.

**Quality and excellence:**

Quality must not be confused with excellence. One could, for instance, set out to produce a low quality product by legitimately using quality control to ensure that the product remains consistently at that quality level and did not drift into the quality higher or lower than that planned.

**Quality accreditation:**

Quality accreditation requires not only good quality control but also tangible evidence to show its effectiveness and to convince a potential customer that product quality is under control.

**The cost quality:**

Quality and the cost of attaining it must be measured and evaluated objectively in the same way as other facets of the firm. All cost associated with quality and its control is very important. There are three categories of quality cost that are identifiable:

- Prevention and preparation
- Measurement and analysis
- Failures and rectification

After identifying the categorizing of the quality cost, a balance sheet of quality is drawn to establish how much is being spent as the starting point for any evaluation of benefits of the quality operation.

**Monitoring quality:**

To minimize error during manufacturing, it is essential to check for the required quality, which can be achieved by:

- Inspection during manufacturing
- Analysis of substandard garments
- Analysis of customer returns

**Measure defect rate:**

It should relate to the number of products involved in the inspection as this enables fault rate comparison at different stages of production.

**Defect analysis:**

Defect analysis means that various inspection/monitoring activities form the basis for decision and action about correcting any faults found and seeking to prevent their recurrence.

**Parameters of quality**

Quality is an important factor which customer looks for in a product to give total satisfaction. Some of the important parameters of quality are:

- **Performance:** Must satisfy a customer under normal working conditions by virtue of its ability to achieve the desired results or service.
- **Features:** Product must be able to offer or give the expected performance easily and comfortably under normal operating conditions.
- **Reliability:** Reliability ensures optimum performance of product without frequent failures and without any constant attention, adjustment or maintenance.
- **Conformance:** Ensures the dimension of quality adherence of a product to the stipulated specification or performance.
- **Durability:** Durability ensures the life span of the product over which it is enabled to offer the optimum performance.
- **Serviceability:** Offers an uninterrupted performance of the product by way of prompt and competent service.
- **Aesthetics:** Contributes to the customers' satisfaction.
- **Perceived quality:** Involves the image, advertisements, brand names etc, which influence expectations and confidence of the customer to go for a particular product.



## **Quality control aspects of production:**

### **Finished leathers:**

As finished leathers are the raw materials for manufacturing leather goods, the customer expects the quality of the finished leathers in terms of durability, aesthetic appearance and fashion appeal. The quality of finished leathers is measured in terms of properties by visual examination. This includes smoothness of grain, colour, uniformity of dyeing, grain cracking, softness, fullness and any other defects. The quality of leather is also measured in terms of physical properties such as tensile strength, tear strength, grain crack resistance, water vapour permeability, rub fastness, finish adhesion strength, light fastness, abrasion resistance etc. As most of the leather products are exported, finished leathers, which form a major part of the raw materials, must possess the following properties before they could be used in making leather products:

### **Feel:**

The feel of leather is tested by feeling up in the palm at different places.

### **Adhesion to finish:**

Scotch tape of 5” is stuck to about 4” on the grain side of the leather and then pressed well. The loose end of the tape is ripped off in one quick motion. The tape is checked to see if any finish is sticking to the tape from the stuck surface of the leather. Poor adhesion of finish can give rise to flaking and peeling of finish in use.

### **Cracking:**

The leathers are double folded at least in 4 places to see whether there is a tendency of pigment or grain cracking.

### **Dry and wet rub:**

The grain side is rubbed vigorously with a piece of white fabric and the cloth is examined for any transfer of finish after rubbing. The cloth is wet and then rubbed on the grain side at some place to find out any transfer of finish on the wet cloth. This involves the assessment of the change in shade of the leather after testing. The degree of change of colour is assessed by using grey scales.

#### **Colour fastness to rubbing**

- Dry 150 rubs – min. 3 grade for upper
- Wet 50 rubs – min. 3 grade for upper leather
- Dry 50 rubs – min. 3 grade for suede leather
- Wet 20 rubs – min. 3 grade for suede leather
- Dry 50 rubs – min. 3 grade for napa leather
- Wet 20 rubs – min. 3 grades for napa leather

### **Scuff resistance:**

The resistance of leather to damage under impact is measured using scuff resistance test.

**Strength:**

A small cut is made on the butt region and the leather is torn with fingers by pulling strongly on either side. The effort is compared with that required reference of strength. (Min. 35-40 kg/cm).

**Fading:**

In case of white or light coloured leather, the leather piece is kept in the sun for 3 hours and compared it with the original piece for fading (Yellow or change of colour). The performance of leather surface to resist fading to light is compared to a standard wool scale to give a performance rating. Pigment finished systems will usually perform better than aniline dye type finishes.

**Water absorption:**

A small piece of the leather is dipped in water for 5 minutes and the amount of water absorbed by it is measured by Bally Permeometer. The grain side of the piece is rubbed with a piece of fabric to see physical determinants. Water absorption test is carried out for both upper and garment leathers using Penetrometer and the standards prescribed for water absorption test are strictly followed.

Bally Permeometer and Penetrometer for upper and garment leathers to water:

- Penetration time - minimum 60 minutes for upper.
- Water absorption percentage – maximum 80% for 60 minutes for upper
- (The above test is not applicable to garment leathers)

**Water repellent:**

This test is mainly applicable to clothing leather and measures the shower proof. It is carried out by spraying water on a piece of leather under controlled conditions and comparing the effect with a standard.

**Chemical resistance:**

Some water is dropped on the grain side of a piece of leather and dried. Later natural rubber adhesive, synthetic neoprene rubber adhesive etc are applied and allowed to dry. The piece is then rubbed with a crepe rubber to see any damage to the finish.

**Tensile strength:**

It is one of the important properties to evaluate the quality of leather. Good quality of leather is expected to have a minimum tensile strength - min. 20N/mm.square. The value below, which indicates poor quality of leather fibre weave.

**Stitch-tear strength:**

Stitch tear strength is determined to assess the strength of the leather during stitching of leather components for making leather products. Stitch tear strength of the leather must be 100N/mm.

**Abrasion resistance:**

It is carried out by using carborandum-coated paper as abrading material and is done using abrasion testing machine.

**Elongation at break:**

It is the indication that leather can stretch or wear before it is broken. Elongation at break must be 45 – 85%

**Water vapour permeability:**

This property is important from comfort point of view and is measured for upper, garment lining leather etc by water vapour permeability apparatus Water Vapour permeability (Herfeld) min.300 for upper leathers and 350 for garment leathers. It is a test to determine the amount of water vapour that a material will transmit through its structure in a specified time. This is an important performance measurement for leathers as it will determine the category/type of the leathers and subsequently the performance standards it must need.

**Fittings, linings and accessories**

Superior branded quality of fittings, linings and accessories, which have long-life with smooth working performance, must always be used. Especially fittings must be resistant to fading and rusting.

**Mechanical process:**

Adhering to strict operational instruction and periodical maintenance of machines, the quality control by mechanical operation is assessed. The mechanical operations in various

**Elongation at break:**

It is the indication that leather can stretch or wear before it is broken. Elongation at break must be 45 – 85%

**Fittings, linings and accessories**

Superior branded quality of fittings, linings and accessories, which have long-life with smooth working performance, must always be used. Especially fittings must be resistant to fading and rusting.

**Mechanical process:**

Adhering to strict operational instruction and periodical maintenance of machines, the quality control by mechanical operation is assessed. The mechanical operations in various stages of leather goods manufacturing also influence the quality of leather goods to a great extent. These operations include clicking, splitting, skiving, strap cutting, ironing and a variety of machines used to impart certain desirable properties.

**Cutting process:**

The cost of finished leathers average 50% of the cost of the producing leather goods. Hence, savings in the finished leathers should always be sought. Cutting costs can be reduced considerably through consistently accurate cutting which reduces the need for additional manipulation of incorrectly cut parts. Quality in cutting is a vital part of any quality control program and is potentially easier to control because of the smaller number of people involved. But the cost of poor quality control can be extremely serious, as

many errors cannot really be rectified. The task of bundling can be an important step in controlling quality by avoiding mixing parts of different sizes and shades.

The purpose of deploying inspectors in cutting room is:

- to locate the source of bad work
- to have defective work corrected
- to prevent the production of further defective work

### **Assembling process:**

The quality of assembling process is assessed by conformity of the products to the standards and specifications. Inspection points are selected according to the method of leather goods construction in use and after analysis of faulty work. Since inspection may not be practicable or necessary at every work place, it should take place frequently enough to keep the cost of repairs involved to minimum. To wait until final viewing can be more costly than a sample check at the right place in the production chain.

### **Stitching process:**

Quality control of stitching is assessed by using appropriate thread numbers with considerable strength and colour-matching threads. Quality control of stitching is also assessed by stitch appearance and stitch length-specifications (e.g. stitch per inch) depending upon types of products.

### **Finishing process:**

Quality control of finishing is assessed by final inspection and testing as per laid down sampling procedures. By adopting strict quality control measures during different stages of processing, it is possible to achieve the desired requirements of the finished products as per standards and specifications.

### **Line quality control:**

Regular hourly inspections are carried out in the processing line starting from the first operation of selection and inspection of leathers to finished products. The faults occurring in between the process are recorded and remedial measures are taken to rectify the defects immediately.

### **Stage quality control:**

Stages are created viz. first stage, second stage, third stage etc. for regular inspection at predetermined points of problem areas depending upon the need and importance. If defects are noticed in anyone of the stages, the process is stopped for corrective action.

### **Final quality Control:**

The finished products are thoroughly checked for 100% perfection. If the product does not conform to the standards and specifications, the product is rejected.

### **Acceptable quality level:**

Random checks or check as per sampling plan is carried out for acceptable quality level. If the samples do not satisfy the acceptable quality level, they are sent for necessary

corrective action. If the samples are found to be good, they are sent for consignment inspection.

**Monitoring and inspecting:**

Monitoring is vital in providing the data which shows how well the specifications are being met. From this data, it is possible to decide the correct items to inspect which operations to check and how frequently this should be done to provide the desired precision of control. The final inspection of these to ensure an acceptable quality of work is by no means quality control. Quality control may, of course, include an element of final inspection and it is essential that this be properly organized and controlled.

**Warehousing:**

It is a vital area as sloppy packing and paper work or bad warehouse conditions can ruin all the good work done in earlier operations.

**Returns to manufacturer:**

It is vital to treat every product returned from the customer very seriously. The study reports of returns reveal that good companies dispatch about 2 to 5% of the faulty goods.

**Good housekeeping:**

Good housekeeping is essential to project the image of the company. Soiled or stained goods delivered due to bad housekeeping will affect the image of the company.

# Chapter 9

## Projects for making products

The last chapter “An outline for small products making” describes about making small leather goods with different construction techniques for the artisans to select from. They range in complexity from basic to quite involved. The process for making leather goods in this chapter applies the information and techniques presented in the preceding chapters. Tools like stainless steel scales, cutting knife, scissors, punches, creasing tool, riveting tool, eyeleting tool, button fitting tool light weight hammer, etc. and also machines like splitting, skiving, sewing, etc. are also used for making the following leather goods. Patterns are used for cutting components, marking center-marks to facilitate easy assembling processes, making holes for fixing fittings on the components and folding components accurately. Short outlines of step-by-step approach to make a few products are provided below but to master the skill in fabricating techniques of products making, it is necessary to have an intense practical experience in making a wide variety of products using different techniques, sophisticated tools, equipments and machines.



**1. Change purse:** An attractive change purse can be easily constructed from a small amount of leathers. It is a good project to begin with. It helps in establishing basic knowledge and fabricating technique.

**Specification:**

**Size - 14 cm.x11.5 cm.x3 cm. (Cut-edged construction):**

**Raw materials:**

**i. Finished leathers:** cow upper / cow softy upper/goat upper/goat softy

**ii. Accessories:** Purse buttons, thread, mica, matching colour pigment/dye and adhesive

**Preliminary operations:**

Pattern cutting, leather components cutting, splitting, skiving, creasing and staining

**Fabrication process:**

i. Front pockets assembly with gusset, using adhesive and stitching

ii. Front panel slotting for coins

iii. Front and back panel assembly, using adhesive and trimming excess leather while bending the assembly

iv. Attaching the pockets and window panel to the assembled front and back panel assembly, using adhesive

v. Stitching the whole assembly

vi. Marking holes for buttons fixing and punching the holes with the punching tool

vi. Fixing the buttons and inserting the mica piece into the window panel

**Finishing process:**

i. Fusing the excess thread and removing the excess adhesive

ii. Rubbing the edges with smooth emery paper

iii. Staining the edges with matching colour pigments/dyes. Rubbing the edges with wax polish after colour drying. Rubbing the edges vigorously for glossiness with a piece of smooth cloth

**2. Key case:** Key cases are small and useful to hook keys. Key cases are fabricated in a variety of designs and shapes with attractive fittings. It can be made from a small amount of leathers.

**Specification:**

**Size:** 16cm.x10cm. (Cut-edged construction)

**Raw materials:**

**i. Finished leathers:** Cow upper/softy, Goat upper/softy

**ii. Accessories:** eyelets, purse button, thread, matching colour pigment/dye and adhesive

**Preliminary operations:**

Pattern cutting, leather components cutting, splitting, skiving, creasing and staining

**Fabrication:**

i. Marking holes, punching and fixing key hook in the middle panel, using eyelets

ii. Top, middle and bottom components assembly with the back panel, using adhesive and stitching

iii. Marking holes, punching and fixing the button

**Finishing:**

i. Removing the excess adhesive and fusing the excess thread

ii. Smoothing edges with emery paper

iii. Staining edges with matching colour pigments/dyes

iv. Rubbing the edges with wax polish after colour drying

v. Rubbing the edges with a piece of smooth cloth for glossiness

**3. Coin pouch:** It is a beautiful, small and useful to carry coins for petty shopping. It is usually made from garment leather waste. A variety of colour combinations are given while fabricating to make the pouches attractive.

**Specification:**

**Size -** 13cm x 5.5cm (turn – edge construction)

**Raw materials:**

- i. **Finished leathers:** garment leather waste
- ii. **Accessories:** No.3 nylon zip, No.3 runner, thread and adhesive

**Preliminary operations:**

Pattern cutting, leather components cutting

**Fabrication:**

- i. Zip attaching to the centre panel and stitching
- ii. Components assembling on the reverse (flesh) side, using adhesive
- iii. Stitching
- iv. Turning the pouch to the front (grain) side and hammering gently at the stitched ends for perfect shaping

**Finishing:**

- i. Removing the excess adhesive and fusing the excess thread
- ii. Cleaning the pouch with a piece of smooth cloth

#### **4. Gents belt:**

Belts are in use from ancient civilization to modern time. Belts can be made wide or narrow, plain or printed, conventional or colourful according to the choice and fashion trends. Belts are made using different techniques of constructions such as cut-edged, butt-edged and fold-edged.

#### **Specification:**

**Size:** 110cm x 3.0cm (Fold – edge construction }

#### **Raw materials:**

- i. **Finished leathers:** cow upper/cow softy upper
- ii. **Accessories:** Belt buckle, purse buttons, thread, matching colour dye and adhesive

#### **Preliminary operations:**

Pattern cutting, straps cutting (top, bottom, reinforcement and loops), splitting skiving and staining

#### **Fabrication:**

- i. Trimming the ends of the top, bottom and reinforcement straps with the pattern
- ii. Joining the top belt strap with reinforcement strap, using adhesive
- iii. Folding the top strap over the reinforcement strap accurately and hammering gently on the folded edges
- iv. Joining the bottom lining strap with top belt strap assembly, using adhesive and hammering gently on the joined edges throughout the length of the strap
- v. Stitching
- vi. Marking for punching holes to fix belt buckle and buttons and to insert buckle prong into the suitable hole for waist tightening
- vii. Punching holes on the marks, using suitable punching tools
- viii. Fixing Buttons and buckle
- ix. Assembling the loops either by using synthetic adhesive and stitching or by stapling the assembled loops in the stapling machine

#### **Finishing:**

- i. Removing the excess adhesive and fusing the excess thread
- ii. Staining the punched holes with matching colour pigment/dye
- iii. Cleaning the belt with a piece of smooth cloth

**5. Gents wallet:** Billfold or a wallet comes in a variety of designs. It is very useful to carry currencies, credit cards, ID cards, business cards etc

**Specification:**

**Size:** 21.5c.m x 9.5c.m (Fold- edge construction)

**Raw materials:**

- i. **Finished leathers:** Cow softy upper/ goat softy upper/ sheep napa
- ii. **Accessories:** Mica sheet, silk/imitation suede lining, thread, matching colour dye and adhesive

**Preliminary operations:**

Pattern cutting, leather and lining components cutting, mica piece cutting, splitting, skiving and staining

**Fabrication:**

- i. Window panel assembly with mica piece, using adhesive
- ii. Stamp pocket and business card pockets assembly with lining, using adhesive
- iii. Front panel assembly with lining and centre leather piece, using adhesive and stitching
- iv. Credit card pockets assembly and attaching the credit card pockets and window panel assembly with the front panel, using adhesive
- v. Piping the centre panel top, left side of the pockets and right side of the window panel with mica, using adhesive and stitching
- vi. Divider assembly with lining and top leather strap, using adhesive and then stitching
- vii. Back panel assembly with lining
- viii. Attaching front panel and divider assembly to the back panel assembly, using adhesive
- ix. Folding the back panel assembly on all sides, leaving a small width in the centre at the bottom for final folding
- x. Hammering gently at the folded edges
- xi. Stitching on all sides except at the bottom where a small width is left to prevent wrinkles while folding the wallet
- xii. Closing the unstitched width by pushing it over the back panel lining through the gap, using synthetic adhesive

**Finishing:**

- i. Removing the excess adhesive and fusing the excess thread
- ii. Finishing the trimmed edges with the matching colour pigment/dye by staining
- iii. Cleaning the product with the piece of smooth cloth

## REFERENCES

1. **Leather Craft - Introduction to Embossing system and Stamping** ---- **Leather Goods Development -cum- Demonstration Centre, UNDP/UNIDO Assisted Project, Central Leather Research Institute, Adyar, Chennai, India – 1979**
  
2. **Bag Tanning Processes** ---- **Central Leather Research Institute, Adyar, Chennai, India - 1983**
  
3. **Training in tanning techniques and Leather Goods Manufacture** ---- **Course Material for Technical Cooperation and Common Wealth Science Council, Central Leather Research Institute, Adyar, Chennai, India – 1990**
  
4. **Technical sheets for Leather Goods** ---- **AFPIC (National Association) for Vocational Training in Leather Industries, France – 1993**
  
5. **Leather Garments Pattern Designing** ---- **Course Material, CLAD, Central Leather Research Institute, Adyar, Chennai, India- 1995**
  
6. **Refresher Training Programme for KVIC and KVIB on Leather processing and Leather Products Manufacturing at CLRI, Chennai And Gandhi Niketan, Centre for Vocational training – The Kallupatti** ---- **Course Material – CLAD, Central Leather Research Institute, Adyar, Chennai, India – 1998**